

*Contains*

# **Operating Manual**

*for*

## **COUNTER POWER METER CPM 20 and CPM 46**

**Part number 46882-335F  
Issue 10**

**Creation date 27-Jan-00**



---

# COUNTER POWER METER CPM 20 and CPM 46

© IFR Ltd. 2000

*No part of this book may be reproduced or transmitted in any form or by any means, electronic or mechanical, including photocopying, or recorded by any information storage or retrieval system, without permission in writing by IFR Ltd.*

Printed in the UK

Manual part no. 46882-335F  
Issue 10

27 January 2000

---

# CONTENTS

## PRECAUTIONS

Chapter 1 GENERAL INFORMATION

Chapter 2 INSTALLATION

Chapter 3 OPERATION

Chapter 4 BRIEF TECHNICAL DESCRIPTION

Chapter 5 ACCEPTANCE TESTING

Appendix A USING THE TERMINAL INTERFACE

## INDEX

---

# PRECAUTIONS

**WARNING**

**CAUTION**

**Note**

These terms have specific meanings in this manual:

**WARNING**

**information to prevent personal injury.**

**CAUTION**





**information to prevent damage to the equipment.**

**Note**

**important general information.**

## Hazard symbols

The meaning of hazard symbols appearing on the equipment is as follows:

Symbol	Nature of hazard
	General hazard
	Toxic hazard
	Corrosive hazard
	Class II supply
	Static sensitive components

## General conditions of use

This instrument is designed to comply with the requirements of IEC/EN61010-1, ‘Safety requirements for electrical equipment for measurement, control and laboratory use’, for Class III portable equipment and is for use in a pollution degree 2 environment. The equipment is designed to operate from an installation Category I supply.

Equipment should be protected from the ingress of liquids and precipitation such as rain, snow, etc. When moving the instrument from a cold to a hot environment, it is important to allow the temperature of the instrument to stabilise before it is connected to the supply to avoid condensation forming. The instrument must only be operated within the environmental conditions specified in Chapter 1 ‘Performance Data’.

This product is not approved for use in hazardous atmospheres or medical applications. If the equipment is to be used in a safety-related application, e.g. avionics or military applications, the suitability of the product must be assessed and approved for use by a competent person.

**WARNING**



### **Electrical hazards (DC supply voltage)**

This equipment conforms with IEC safety Class III, meaning that for continued safety it must only be connected to supplies and signal sources which conform to ‘Separated Extra-Low Voltage’ (SELV and SELV-E) voltage and insulation

---

requirements. No hazardous voltages are generated internally. See under 'Performance Data' in Chapter 1 for the maximum permitted voltage levels that can be applied.

Do not remove covers, no user-serviceable parts inside. See list of IFR Ltd. International Service Centres at rear of manual.

**WARNING**



## Nickel Metal Hydride

A Nickel Metal Hydride (Ni-MH) battery pack is used in this equipment. Do not attempt to open, disassemble or mutilate the battery pack. The battery pack does not contain any user serviceable components and cannot be repaired. Under abnormal conditions, the battery pack can explode, leak or catch fire if exposed to high temperatures/fire, or if it is opened or disassembled. Do not short circuit the battery pack terminals.

This battery pack contains an absorbed CORROSIVE potassium hydroxide electrolyte which can cause burns to the eyes and skin, and nickel hydroxide which is HARMFUL if inhaled or if it comes into contact with the skin, resulting in possible sensitisation of the affected area. In all cases, rinse the affected area with plenty of water and seek medical advice. Use protective gloves when handling a damaged battery.

If the battery has leaked or vented, it must be replaced immediately. Replace only with an identical battery from the same manufacturer or with a type recommended by IFR Ltd. Remove the instrument power lead before removing the battery pack.

The battery pack contains a smart charge management system and must only be charged using the charging facilities in the equipment, or by using an approved battery charger.

European legislation (EC Directive 91/689/EEC) classifies Ni-MH batteries as hazardous waste due to the nickel content. Collect spent batteries separately for disposal, do not mix with other waste streams. Contact your local battery supplier for up-to-date information on the collection, disposal or recycling procedures for your country.

**WARNING**



## Toxic hazards

Some of the components used in this equipment may include resins and other materials which give off toxic fumes if incinerated. Take appropriate precautions, therefore, in the disposal of these items.

---

**WARNING****Power adapter**

The supplied power adapter has been designed and tested in accordance with IEC 950 (BS EN 60950, UL 1950 and CAN/CSA C22.2 No. 234) 'Safety of information technology equipment, including electrical business equipment', and meets the SELV requirements of products with low voltage DC supply inputs. The adapter conforms with IEC Safety Class II incorporating double insulation in its construction, and does not require a protective ground connection; it is only suitable for indoor use.

No user serviceable parts are contained within the adapter and no attempt should be made to open the case. Should a replacement adapter be needed, please refer to your local IFR Ltd Sales Office.

Where the equipment carries a Third Party product safety approval (for example, UL3111-1), this approval will be invalidated if the equipment is used with a power adapter that does not have the same ratings and approvals as the adapter supplied by IFR Ltd or if the equipment is operated in conditions outside those specified in Chapter 1.

Where a supply lead is fitted to adapters incorporating an integrally fused plug ensure that the fuse rating is commensurate with the current requirements of the lead. See under 'Installation' in Chapter 2 for current rating.

**CAUTION****LCD handling**

When using this equipment take care not to depress the front of the display module, as this may damage the liquid crystal elements.

**CAUTION****Static sensitive components**

This equipment contains static sensitive components which may be damaged by handling - refer to the Maintenance part of the Service Manual for handling precautions.

**CAUTION****Precision connector**

The precision Type N or 2.92 mm connector fitted to this instrument may be damaged by mating with a non-precision type. Damage to the connector may also occur if the connector interface parameters are not within specification. The connector should be checked with the appropriate gauging tool.

---

# Précautions

**WARNING**

**CAUTION**

**Note**

Les termes suivants ont, dans ce manuel, des significations particulières:

**WARNING**

**contient des informations pour éviter toute blessure au personnel.**

**CAUTION**





**contient des informations pour éviter les dommages aux équipements.**

**Note**

**contient d'importantes informations d'ordre général.**

## Symboles signalant un risque

La signification des symboles liés à cet équipement est la suivante:

Symbole	Nature du risque
	Risques généraux
	Danger produits toxiques
	Corrosive hazard
	Classe II équipement

## Conditions générales d'utilisation

Ce produit a été conçu et testé pour être conforme aux exigences des normes CEI/EN61010-1 "Règles de sécurité pour appareils électriques de mesurage, de régulation et de laboratoire", pour des équipements Classe portables et pour une utilisation dans un environnement de pollution de niveau 2. Cet équipement est conçu pour fonctionner à partir d'une alimentation de catégorie I.

Cet équipement doit être protégé de l'introduction de liquides ainsi que des précipitations d'eau, de neige, etc... Lorsqu'on transporte cet équipement d'un environnement chaud vers un environnement froid, il est important de laisser l'équipement se stabiliser en température avant de le connecter à une alimentation afin d'éviter toute formation de condensation. L'équipement doit être utilisé uniquement dans les conditions d'environnement spécifiées dans "Performance data" dans le chapitre 1 du manuel d'utilisation.

Ce produit n'est pas garanti pour fonctionner dans des atmosphères dangereuses ou pour un usage médical. Si l'équipement doit être utilisé pour des applications en relation avec la sécurité, par exemple des applications militaires ou aéronautiques, la compatibilité du produit doit être établie et approuvée par une personne compétente.

---

**WARNING**

## Sécurité électrique (tension d'alimentation continue)

Cet équipement est conforme aux normes de sécurité CEI Classe III, c'est-à-dire qu'il ne doit être connecté qu'à des sources d'alimentation ou de signaux qui suivent les recommandations de tension et d'isolement du type 'Tension extra-faible séparée' (SELV at SELV-E). Aucune tension dangereuse n'est générée en interne. "Performance data" dans le chapitre 1 du manuel d'utilisation précise les niveaux de tension maximum acceptables en entrée.

Ne pas enlever les capots, aucune pièce réparable ne se trouve à l'intérieur. Contacter un des Centres de Maintenance Internationaux de IFR Ltd dans la liste jointe à la fin du manuel.

**WARNING**

## Nickel Hydrure

Un pack batterie au Nickel Hydrure (Ni-MH) est utilisé dans cet équipement. Ne pas écraser, transpercer, ouvrir, démonter ou intervenir mécaniquement de quelque façon que ce soit. Le pack batterie ne contient pas de composants réparables. Sous des conditions anormales, le pack batterie peut exploser, fuir, ou prendre feu si on l'expose aux températures élevées ou au feu, ou si on l'ouvre ou le démonte. Ne pas court-circuiter les bornes.

Ce pack batterie contient un électrolyte hydroxyde de potassium qui est corrosif, pouvant causer des brûlures chimiques aux yeux et sur la peau, ainsi que de l'hydroxyde de nickel qui est nocif lorsqu'il est inhalé ou en contact avec la peau. En cas de contact avec la peau, laver immédiatement la surface touchée avec beaucoup d'eau et s'adresser à un service médical. Utiliser des gants de protection lorsque l'on touche une batterie endommagée.

Si la batterie a eu une fuite ou une ventilation, il faut la remplacer immédiatement. Utilisez seulement une batterie identique du même fabricant ou avec un modèle recommandé par IFR S.A. Débrancher le câble d'alimentation avant de remplacer le pack batterie.

Le pack batterie contient un système de régulation intelligent, donc il faut seulement utiliser le système de rechargement interne ou un chargeur agréé.

Les batteries du type Ni-MH, suivant les Normes Européennes (EC Directive 91/689/EEC), sont considérées comme des déchets dangereux parce qu'elles contiennent du nickel. Garder les batteries qui ne sont plus utilisables séparément; ne les jetez pas avec les déchets industriels ou domestiques. Contacter votre fournisseur local de batteries pour tout renseignement sur les procédures de rassemblement, enlèvement ou recyclage dans votre pays.

---

**WARNING** **Danger produits toxiques**

Certains composants utilisés dans cet appareil peuvent contenir des résines et d'autres matières qui dégagent des fumées toxiques lors de leur incinération. Les précautions d'usages doivent donc être prises lorsqu'on se débarrasse de ce type de composant.

**WARNING** **Adaptateur secteur**

L'adaptateur secteur fourni avec l'appareil a été conçu et testé en conformité avec la norme IEC 950 <BSEN 60950, UL 1950 et CAN/CSA C22.2 N°234> Sécurité d'équipements de technologie de l'information et équipements électriques industriels” et suit les recommandations “SELV” des produits comportant des entrées continues à faible voltage. L'adaptateur possède d'origine une double isolation conformément à la norme CEI “Sécurité Classe II”, ne requière pas de retour à la masse ; il n'est utilisable que sous abri.

L'adaptateur ne contient pas de composants réparables et il faut absolument éviter de l'ouvrir. S'il y a besoin de le remplacer, renseignez vous auprès de votre agent local IFR.

Si l'équipement comporte un troisième niveau d'agrément ( par exemple : UL3111-1), cet agrément peut être annulé en cas d'utilisation avec un adaptateur secteur qui n'aurait pas le même niveau d'agrément que l'adaptateur secteur fourni par IFR ou si l'équipement est utilisé dans des conditions non spécifiées au chapitre 1.

Lorsque le câble d'alimentation connecté à l'adaptateur contient un fusible, il faut vérifier qu'il soit bien dimensionné. Voir “Installation” au chapitre 2 pour la valeur du fusible.

---

# Vorsichtsmaßnahmen

**WARNING**

**CAUTION**

**Note**

Diese Hinweise haben eine bestimmte Bedeutung in diesem Handbuch:

**WARNING**

**dienen zur Vermeidung von Verletzungsrisiken.**

**CAUTION**

**dienen dem Schutz der Geräte.**

**Note**

**enthalten wichtige Informationen.**

## Gefahrensymbole

Die Gefahrensymbole auf den Geräten sind wie folgt:

**Symbol**

**Gefahrenart**



Allgemeine Gefahr



Warnung vor giftigen Substanzen



Ätzend



Netzversorgung Klasse II

## Allgemeine Hinweise zur Verwendung

Dieses Produkt wurde entsprechend den Anforderungen von IEC/EN61010-1 “Sicherheitsanforderungen für elektrische Ausrüstung für Meßaufgaben, Steuerung und Laborbedarf”, Klasse III, transportabel zur Verwendung in einer Grad 2 verunreinigten Umgebung, entwickelt und getestet. Dieses Gerät ist für Netzversorgung Klasse I zugelassen.

Das Meßgerät sollte vor dem Eindringen von Flüssigkeiten sowie vor Regen, Schnee etc. geschützt werden. Bei Standortänderung von kalter in wärmere Umgebung sollte das Meßgerät wegen der Kondensation erst nach Anpassung an die wärmere Umgebung mit dem Netz verbunden werden. Das Meßgerät darf nur in Umgebungsbedingungen wie in Kapitel 1 “Leistungsdaten (Performance data)” der Bedienungsanleitung beschrieben, betrieben werden.

Dieses Produkt ist nicht für den Einsatz in gefährlicher Umgebung (z.B. Ex-Bereich) und für medizinische Anwendungen geprüft. Sollte das Gerät für den Einsatz in sicherheitsrelevanten Anwendungen wie z.B. im Flugverkehr oder bei militärischen Anwendungen vorgesehen sein, so ist dieser von einer für diesen Bereich zuständigen Person zu beurteilen und genehmigen.

---

**WARNING** **Elektrische Schläge (Gleichspannungsversorgung)**

Dieses Gerät entspricht der IEC Sicherheitsklasse III. Aus Sicherheitsgründen darf es nur an Netzgeräte und Signalquellen angeschlossen werden, die in Spannung und Isolation der SELV und SELV-E Richtlinie genügen (“Getrennte Niederspannung”). Im Gerät werden keine gefährlichen Spannungen erzeugt. Im Handbuch, Kapitel 1, “Performance Data” (Leistungsdaten), werden die anschließbaren Höchstspannungen definiert.

Entfernen Sie keine Gehäuseabdeckungen, es befinden sich keine austauschbaren Teile im Gerät. Eine Liste der IFR Servicestellen finden Sie auf der Rückseite des Handbuchs.

**WARNING**  **Nickel Metalhydride**

In diesem Gerät wird ein Nickel-Metalhydrid (Ni-MH) Akkusatz verwendet. Versuchen Sie nicht diesen zu öffnen, auszubauen oder zu zerstören. Der Akkusatz beinhaltet keine vom Anwender auszutauschenden Teile und kann auch nicht repariert werden. Unter abnormalen Bedingungen kann der Akkusatz, falls ausgebaut oder geöffnet, explodieren, auslaufen oder bei hohen Temperaturen auch Feuer fangen. Schließen sie die Akkuanschlüsse niemals kurz.

Der Akkusatz enthält neben einem ätzenden Kalium-Hydroxid Elektrolyten welcher Verätzungen des Auges und der Haut hervorrufen kann auch Nickel-Hydroxid welches sich bei Einatmung zur Schädigungen führt oder Berührung mit der Haut eine Reizung des betroffenen Bereiches bewirkt. In allen Fällen ist die betroffene Stelle mit ausreichend Wasser zu berieseln und ärztliche Hilfe in Anspruch zu nehmen. Verwenden Sie bei der Handhabung von beschädigten Akkus Schutzhandschuhe.

Sollte der Akkusatz auslaufen oder eine mechanische Beschädigung aufweisen, so ist er umgehend zu entfernen. Ersetzen Sie diesen nur durch einen identischen Akkusatz des gleichen Herstellers oder mit einem Typ wie er von IFR empfohlen wird. Stecken Sie vor dem Entfernen des Akkusatzes das Netzkabel aus.

Der Akkusatz enthält eine spezielles Ladeüberwachungsschaltung und darf nur mit der Ladeeinrichtung des zugehörigen Gerätes oder einem passenden Ladegerät geladen werden.

Die Europäische Gesetzgebung (EC Richtlinie 91/689/EEC) stuft Ni-MH Akkus wegen ihres Anteils an Nickel als gefährlichen Abfall ein. Sammeln Sie verbrauchte Akkus getrennt und mischen Sie diese nicht mit anderem Abfall. Fragen Sie den in Ihrem Land zuständigen Hersteller bezüglich Sammlung, Entsorgung und Wiederaufarbeitung von verbrauchten Akkus.

---

**WARNING****Warnung vor giftigen Substanzen**

In einigen Bauelementen dieses Geräts können Epoxyharze oder andere Materialien enthalten sein, die im Brandfall giftige Gase erzeugen. Bei der Entsorgung müssen deshalb entsprechende Vorsichtsmaßnahmen getroffen werden.

**WARNING****Netzadapter**

Der mitgelieferte Netzadapter ist entsprechend der Norm IEC 950 BS EN 60950, UL 1950 und CAN/CSA C22.2 No. 234 für die Sicherheit datentechnischer Anlagen, inklusive elektrischer Büromaschinen, ausgelegt und getestet worden. Er entspricht den "SELV" Richtlinien für Geräte mit niedrigen Gleichspannungsversorgungen. Der Adapter entspricht mit doppelter Isolation der IEC Sicherheitsklasse II und benötigt keinen Masse-Schutzleiter; er darf nur innerhalb von Räumen verwendet werden. .

Der Adapter enthält keine reparier- oder austauschbaren Teile und darf nicht geöffnet werden. Sollte ein Ersatz erforderlich sein, setzen Sie sich bitte mit der nächstgelegenen Niederlassung von IFR in Verbindung.

Sollte ein Gerät ein Sicherheitsprüfzeichen von dritter Seite (z.B. UL3111-1) aufweisen, und wird dieses Gerät mit einem Netzadapter betrieben welcher nicht die gleichen elektrischen Werte und Prüfzeichen wie der von IFR gelieferte Netzadapter aufweist, so wird dieses von dritter Seite vergebene Prüfzeichen ungültig. Gleiches gilt für einen Betrieb welcher nicht die Bedingungen wie in Kapitel 1 spezifiziert, erfüllt.

Falls ein Netzkabel und ein Stecker mit eingebauter Sicherung verwendet werden, beachten Sie bitte, daß die Sicherung den elektrischen Werten des Adapters entspricht. Weitere Information zur Leistungsaufnahme finden Sie unter "Installation" in Kapitel 2.

---

# Precauzioni

**WARNING**

**CAUTION**

**Note**

Questi termini vengono utilizzati in questo manuale con significati specifici:

**WARNING**

**riportano informazioni atte ad evitare possibili pericoli alla persona.**

**CAUTION**





**riportano informazioni per evitare possibili pericoli all'apparecchiatura.**

**Note**

**riportano importanti informazioni di carattere generale.**

## Simboli di pericolo

Significato dei simboli di pericolo utilizzati nell'apparato:

Simbolo	Tipo di pericolo
	Pericolo generico
	Pericolo sostanze tossiche
	Pericolo, sostanze corrosive
	Apparato di classe II

## Condizioni generali d'uso

Questo prodotto è stato progettato e collaudato per rispondere ai requisiti della direttiva IEC/EN61010-1 'Safety requirements for electrical equipment for measurement, control and laboratory use' per apparati di classe III portatili e per l'uso in un ambiente inquinato di grado 2. L'apparato è stato progettato per essere alimentato da un alimentatore di categoria I.

Lo strumento deve essere protetto dal possibile ingresso di liquidi quali, ad es., acqua, pioggia, neve, ecc. Qualora lo strumento venga portato da un ambiente freddo ad uno caldo, è importante lasciare che la temperatura all'interno dello strumento si stabilizzi prima di alimentarlo per evitare formazione di condense. Lo strumento deve essere utilizzato esclusivamente nelle condizioni ambientali descritte nel capitolo 1 'Performance Data' del manuale operativo.

Questo prodotto non è stato approvato per essere usato in ambienti pericolosi o applicazioni medicali. Se lo strumento deve essere usato per applicazioni particolari collegate alla sicurezza (per esempio applicazioni militari o avioniche), occorre che una persona o un istituto competente ne certifichi l'uso.

---

**WARNING** **Pericoli da elettricità (alimentazione a c.c.)**

Questo strumento rispetta le norme IEC, classe III, e quindi, per una completa sicurezza, deve essere collegato solo ad alimentatori e generatori di segnali che rispettano I requisiti di tensione ed isolamento SELV e SELV-E (Separated Extra-Low Voltage). Nessuna tensione pericolosa è generata al suo interno. Vedi capitolo 1 per quanto concerne I livelli massimi di tensione applicabili.

Non rimuovere i coperchi, utilizzare solo parti di scorta originali. Vedi elenco internazionale dei Centri di Assistenza in fondo al manuale.

**WARNING**  **Nickel-Metallo Idrido**

Quest'apparato contiene un pacco batterie al Nickel-Metallo Idrido (Ni-MH, Nickel Metal Hydride) che non deve essere aperto, disassemblato o mutilato di alcuna parte. Il pacco batterie non contiene parti riutilizzabili né può essere riparato. In particolari condizioni (anormali) esso può esplodere, può gocciolare o infiammarsi se esposto ad alte temperature o messo a contatto col fuoco o se aperto o disassemblato. Non corto-circuitare i poli.

Questo pacco batterie contiene idrossido di potassio, un elettrolito **CORROSIVO** che può causare bruciature agli occhi ed alla pelle e sensibilizzare l'area con cui viene a contatto. In ogni evenienza lavare l'area interessata con abbondante acqua corrente e rivolgersi ai consigli di un medico. Usare guanti protettivi quando si maneggia un pacco batterie danneggiato.

Se la batteria gocciola o è forata, va sostituita immediatamente. La sostituzione deve essere fatta solo con analoga batteria, dello stesso costruttore, o con un tipo raccomandato dalla IFR Ltd. Prima di rimuovere la batteria, occorre scollegare il cavo di alimentazione elettrica esterna dell'apparato.

Il pacco batterie contiene un sistema intelligente di ricarica per cui esso va ricaricato solo tramite questo apparato o tramite un carica-batterie approvato.

La legislazione europea (direttiva CE n. 9/889/EEC) classifica le batterie Ni-MH tra i rifiuti pericolosi a causa del suo contenuto di nickel. Le batterie esaurite vanno pertanto raccolte negli appositi contenitori di rifiuti e non vanno mescolate ad altri rifiuti...Contattare il locale fornitore di batterie per le necessarie informazioni sulle procedure vigenti nel Vostro paese sulla raccolta di rifiuti e sull-immagazzinamento di questo tipo di batterie.

---

**WARNING** **Pericolo sostanze tossiche**

Alcuni dei componenti usati in questo strumento possono contenere resine o altri materiali che, se bruciati, possono emettere fumi tossici. Prendere quindi le opportune precauzioni nell'uso di tali parti.

**WARNING** **Carica-batterie**

Il caricabatterie fornito è stato progettato e collaudato secondo le raccomandazioni IEC 950 <(BS EN 60950, UL 1950 y CAN/CSA C22.2 No. 234)> "Safety of information technology equipment, including electrical business equipment" e rispetta i requisiti "SELV" per prodotti alimentati a bassa tensione e a corrente continua. Il caricabatterie rispetta le norme IEC per apparati di classe di sicurezza II con doppio isolamento e non richiede collegamento di terra di protezione, esso può essere usato solo al coperto.

Il caricabatterie non contiene parti sostituibili per cui qualsiasi tentativo di apertura è da evitare. Nel caso sia richiesto un nuovo caricabatterie, si prega di contattare l'ufficio o il rappresentante IFR Ltd locale.

Qualora l'apparato contenga prodotti di terzi con propria approvazione di sicurezza (vedi ad es. UL3111-1), questa sarà invalidata se l'apparato viene usato con un caricabatterie con caratteristiche ed approvazione diverse da quelle del caricabatterie fornito dalla IFR Ltd o se l'apparato viene utilizzato in modo non conforme a quanto riportato al capitolo 1.

Qualora un cavo di alimentazione venga collegato ad un caricabatterie con presa protetta da fusibile, verificare il carrello amperaggio secondo quanto riportato al Capitolo 2 "Installation".

---

# Precauciones

**WARNING**

**CAUTION**

**Note**

Estos términos tienen significados específicos en este manual:

**WARNING**

contienen información referente a prevención de daños personales.

**CAUTION**





contienen información referente a prevención de daños en equipos.

**Note**

contienen información general importante.

## Símbolos de peligro

Los significados de los símbolos de peligro que aparecen en los equipos son los siguientes:

Símbolo	Naturaleza del peligro
	Peligro general
	Aviso de toxicidad
	Corrosive hazard
	Alimentación Clase II

## Condiciones generales de uso

Este producto ha sido diseñado y probado para cumplir los requerimientos de la normativa IEC/EN61010-1 “Requerimientos de la normativa para equipos eléctricos de medida, control y uso en laboratorio”, para equipos clase III portátiles y para uso en un ambiente con un grado de contaminación 2. El equipo ha sido diseñado para funcionar sobre una instalación de alimentación de categorías I.

Debe protegerse el equipo de la entrada de líquidos y precipitaciones como nieve, lluvia, etc. Cuando se traslada el equipo de entorno frío a un entorno caliente, es importante aguardar la estabilización del equipo para evitar la condensación. Sólo debe utilizarse el aparato en las condiciones ambientales especificadas en el capítulo 1 “Especificaciones” o “Performance Data” del Manual de Instrucciones/Manual de Operación/Funcionamiento.

Este producto no ha sido aprobado para su utilización en entornos peligrosos o en aplicaciones médicas. Si se va a utilizar el equipo en una aplicación con implicaciones en cuanto a seguridad, como por ejemplo aplicaciones de aviónica o militares, es preciso que un experto competente en materia de seguridad apruebe su uso.

---

**WARNING**

## **Nivel peligroso de electricidad (tensión de alimentación DC)**

Este equipo cumple con la norma de seguridad IEC clase III, lo que significa que para total seguridad debe ser conectado a alimentaciones y fuentes de señal que cumplan los requerimientos de tensión y aislamiento “Tensión Separada Extra-Baja” (SELV y SELV-E). Ninguna tensión generada internamente implica riesgo para el operario.

En el capítulo 1 “Especificaciones” podrá encontrar los valores máximos permitidos que pueden aplicarse.

No quitar las tapas, en el interior no existen piezas reemplazables por el usuario. Vea la lista de Centros de Servicios Internacionales en la parte trasera del manual.

**WARNING**

## **Níquel Hidruro Metálico (Ni-MH).**

Este equipo utiliza un paquete de baterías híbrido Níquel Hidruro Metálico (Ni-MH). No intente abrir, desmantelar o mutilar el paquete de baterías. El paquete de baterías no contiene ningún componente reemplazable por el usuario y no puede ser reparado. Bajo circunstancias anormales, el paquete de baterías puede explotar, tener fugas o arder si es expuesto a altas temperaturas o fuego o si es abierto o desmontado. No cortocircuite los terminales del paquete de baterías.

Este paquete de baterías contiene un electrolito de hidróxido potásico absorbido corrosivo que puede causar quemaduras en los ojos y en la piel, así como hidróxido de Níquel, que es nocivo por inhalación o por contacto con la piel, produciendo como consecuencia una posible desensibilización del área afectada. En todos los casos, lave la zona afectada con abundante agua y busque consejo médico. Use guantes de protección cuando manipule una batería dañada.

Si el paquete de baterías ha sufrido pérdidas a fugas de gases, debe reemplazarse inmediatamente.

Reemplázela con una batería idéntica del mismo fabricante o con un tipo recomendado por IFR Ltd. Desconecte el cable de alimentación del equipo antes de quitar el paquete de baterías.

---

**WARNING****Aviso de toxicidad**

Alguno de los componentes utilizados en este equipo pudieran incluir resinas u otro tipo de materiales que al arder produjeran sustancias tóxicas. Por tanto, tome las debidas precauciones en la manipulación de esas piezas.

**WARNING****Adaptador de alimentación**

El adaptador de alimentación suministrado ha sido diseñado y probado según la normativa IEC 950 <(BS EN 60950, UL 1950 y CAN/CSA C22.2 No. 234)> “Seguridad en aparatos de tecnologías de la información, incluyendo equipamiento eléctrico de oficinas “ y cumple los requerimientos “SELV” de productos con baja tensión de entrada DC. El adaptador cumple la normativa de seguridad IEC clase II, e incorpora doble aislamiento en su construcción, no requiere conexión a tierra de protección; sólo es adecuado para uso en interiores.

En el interior del adaptador no existen partes reemplazables por el usuario y no debe hacerse ningún intento de abrir la carcasa.

Si el equipo lleva una aprobación de seguridad de un tercero (pro ejemplo UL 3111-1), esta aprobación quedará invalidada si el equipo se utiliza con un adaptador de red de distinto, valores o con distintas aprobaciones a las del adaptador suministrado por IFR Ltd. o si se trabajan con el equipo en condiciones distintas a las especificadas en el capítulo 1.

Si el cable de alimentación tiene una clavija con fusible integrado, asegúrese que el valor del fusible concuerda con la necesidad de corriente del cable. Vea el capítulo 2 "Installation" para el consumo de corriente.

---

# Appendix A

## USING THE TERMINAL INTERFACE

### Introduction

The CPM may be operated remotely via the RS-232 compatible serial interface. A set of commands is available for performing basic frequency, power and voltage measurements.

The interface can be controlled by the simplest form of terminal equipment and is therefore command line driven. The controller can be a PC with a serial port and suitable software.

### Using the RS-232 interface

Connect the controlling terminal equipment via the 9-way D-type connector on the rear panel (see below).

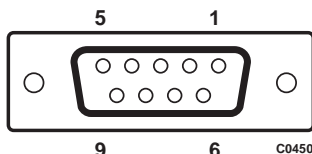

Pin	Pin
1 Not connected	6 Data set ready - DSR
2 Receive data - RX	7 Request to send - RTS
3 Transmit data - TX	8 Clear to send - CTS
4 Data terminal ready - DTR	9 Not connected
6 Signal ground	

Once the connection has been made, the CPM will be ready to accept commands after switching on the unit. When the first command has been sent the unit will be in remote mode, and the current soft key menu will be replaced by a single soft key labelled **[Local]**. Except for this soft key and the Power On/Off key all front panel functions will be disabled. Front panel operation can be restored either by sending the KEY LOCAL command or by pressing the **[Local]** soft key.

### RS-232 characteristics

The serial interface of the controller needs to be set up to match the characteristics of the RS-232 port of the CPM. These are:

Speed:	9600 baud
Data bits:	8
Start bits	1
Stop bits:	1
Parity:	NONE
Handshake	Xon / Xoff

Flow control over the RS-232 interface is achieved via software, using the handshake characters Xon (start transmitting) and Xoff (stop transmitting). All control lines are normally in the OFF state, and are ignored.

## Commands and descriptions

The CPM has a simple, single level command structure. Commands can be entered in lower case, upper case or a mixture of the two. The command string may be followed by a parameter. Each command is terminated with a Carriage Return character (ASCII code 13) by pressing the Enter key; the command will then be executed.

If a command which normally requires a parameter is issued without the value being supplied, the CPM treats the command as a query and returns the current value of the parameter to the terminal. Query responses follow the same format as parameter definitions.

The interface uses '>>' as a prompt and this indicates that the instrument is ready to accept a command.

The following conventions are used in the command descriptions:

Parameter values are shown enclosed in angle brackets <...>.

Optional parameters are shown enclosed in square brackets [...].

Where there is a choice of several items, they are listed, separated by the 'OR' symbol, '|'.

If an error is detected in the entered command, an appropriate error message will be displayed on the terminal

The following is a list of the commands currently available, together with examples of usage:

### DISPLAY FREQ

Perform a frequency measurement and display the result on the terminal. The format will be the same as that of the CPM display

*Example:*

```
>>DISPLAY FREQ
    10.000 000 MHz 0 0 0 0 0
>>
```

The five digits that follow the frequency reading represent other information concerning the measurement and are for servicing use.

### DISPLAY POWER

Perform a power measurement and display the result on the terminal. The format will be the same as that of the CPM display.

*Example:*

```
>>DISPLAY POWER
-38.93 dBm 0 0 0 0 0
>>
```

The five digits that follow the power reading represent other information concerning the measurement and are for servicing use.

<p><b>DISPLAY POWER RANGE [DBM   DBW   W ]</b></p> <p><i>Example:</i></p> <pre>&gt;&gt;DISPLAY POWER RANGE W &gt;&gt;</pre> <pre>&gt;&gt;DISPLAY POWER RANGE POWER RANGE is 'mW' &gt;&gt;</pre>	<p>Set power units.</p> <p>Set power reading units to Watts.</p> <p>Determine the current power reading units.</p>
<p><b>DISPLAY DVM [ON   OFF]</b></p> <p><i>Example:</i></p> <pre>&gt;&gt;DISPLAY DVM ON &gt;&gt;</pre> <p><i>Example:</i></p> <pre>&gt;&gt;DISPLAY DVM DVM is ON 1.35 V &gt;&gt;</pre>	<p>Enable/disable DVM mode.</p> <p>Enable voltage measurements.</p> <p>Perform a voltage measurement and display the result on the terminal. The format will be the same as that of the CPM display. If DVM mode is disabled, this command should be preceded with DISPLAY DVM ON.</p>
<p><b>CMD6970 LF[&lt;lin factor&gt;]</b></p> <p>&lt;lin factor&gt; = floating point number in the range 0.01 to 15</p> <p><i>Example:</i></p> <pre>&gt;&gt;CMD6970 LF7.5 6970 returned 02H [ready for command] &gt;&gt;</pre> <pre>&gt;&gt;CMD6970 LF 6970 returned 02H [ready for command] lin_fac=7.500000 &gt;&gt;</pre>	<p>Set sensor Linearity Factor.</p> <p>Set sensor Linearity Factor to 7.5.</p> <p>Determine the current setting of Linearity Factor.</p>
<p><b>CMD6970 CFC[&lt;50 MHz cal factor&gt;]</b></p> <p>&lt;50 MHz cal factor&gt; = floating point number in the range 0.01 to 200%</p> <p><i>Example:</i></p> <pre>&gt;&gt;CMD6970 CFC98 6970 returned 02H [ready for command] &gt;&gt;</pre> <pre>&gt;&gt;CMD6970 CFC 6970 returned 02H [ready for command] cal_fac 50MHz=98.000000 &gt;&gt;</pre>	<p>Set sensor 50 MHz Calibration Factor.</p> <p>Set 50 MHz Cal Factor to 98%.</p> <p>Determine the current setting of 50 MHz Cal Factor.</p>

## REMOTE OPERATION

---

### **CMD6970 CFM[<cal factor>]**

Set sensor cal factor corresponding to the measurement frequency.

<cal factor> = floating point number in the range 0.01 to 200%

#### *Example:*

```
>>CMD6970 CFM95
6970 returned 02H [ready for
command]
>>
```

Set measurement calibration factor to 95%.

```
>>CMD6970 CFM
6970 returned 02H [ready for
command]
cal_fac=95.000000
>>
```

Determine the current setting of measurement calibration factor.

### **CMD6970 Z**

Perform sensor zero.

#### *Example:*

```
>>CMD6970 Z
COMMAND x% COMPLETED
>>
```

During the zeroing operation the terminal shows its progress as a percentage.

### **CMD6970 C**

Perform sensor calibration.

#### *Example:*

```
>>CMD6970 C
COMMAND x% COMPLETED
>>
```

During calibration the terminal shows its progress as a percentage.

### **CMD6970 P[0 | 1]**

Turn the power reference on/off.

#### *Example:*

```
>>CMD6970 P1
6970 returned 02H [ready for
command]
>>
```

Turn on the power reference.

```
>>CMD6970 P
6970 returned 02H [ready for
command]
Power Ref is ON
>>
```

Determine the power reference status.

### **KEY LOCAL**

Restores front panel operation of the CPM.

#### *Example:*

```
>>KEY LOCAL
>>
```

Return the instrument to local operation.

**RESET**

Restores the CPM to the last power down state. The instrument type, serial number and software revision number are displayed on the terminal.

*Example:*

```
>>RESET
Resetting MMI ... Done
IFR,CPM20,812355/013,
01.06
>>
```

Reset the instrument to the state it was in just after power on.

**\*RST**

Restores the CPM to its default state.

*Example:*

```
>>*RST
Defaulting MMI ... Done
IFR,CPM20,812355/013,
01.06
>>
```

Reset the instrument parameters to their default values/settings.

---

# Chapter 1

## GENERAL INFORMATION

### Contents

Purpose and features of equipment .....	1-1
Introduction .....	1-1
Frequency measurements.....	1-1
Power measurements .....	1-2
Other features .....	1-3
Performance data .....	1-4
Frequency measurements.....	1-4
Power measurements .....	1-5
Digital voltmeter.....	1-7
General .....	1-7
Versions and accessories.....	1-11
Versions.....	1-11
Options .....	1-11
Supplied accessories.....	1-11
Optional accessories .....	1-11
Supported power sensors.....	1-11

### Purpose and features of equipment

#### Introduction

The CPM 20 and CPM 46 Counter Power Meters (CPM) provide simultaneous frequency and power measurements when performing installation and maintenance measurements on communications systems. The instruments are microprocessor controlled and are housed in a portable, rugged case. They are powered from internal rechargeable batteries which provide 3 hours of continuous operation. Batteries can be charged from either the supplied AC charger or a vehicle supply. Measurement and operational details are displayed on a large, easy-to-read dot matrix LCD display.

#### Frequency measurements

The CPM 20 covers the frequency range 10 MHz to 20 GHz, while the CPM 46 extends the upper limit to 46 GHz. This covers IF frequencies through the cellular bands, trunk radio bands and point-to-point radio links. On a standard instrument a digitally controlled temperature compensated crystal oscillator (DTCXO) enables high accuracy measurements to be made. Increased accuracy can be achieved by using a suitable external 10 MHz frequency standard. The resolution at which the measurement is displayed can be selected in decade steps between 1 Hz and 1 MHz.

High input levels on the frequency counter input can be tolerated, with a damage level of +27 dBm (0.5 W). The maximum input level for correct operation of the counter is +10 dBm.

The CPM can also make frequency measurements in the presence of wide FM deviations and large depth AM modulations. Frequency measurements can be made with typically up to 20 MHz pk-pk worst case FM and any AM modulation depth as long as the minimum level does not fall below the sensitivity.

The CPM features automatic amplitude discrimination. This allows the frequency counter to measure the largest signal that is applied to the input ignoring all other signals, as long as the largest signal is at least 20 dB greater than the other signals.

The measurement time for a frequency measurement is 250 ms for a display of >1 Hz resolution, rising to 2 s for 1 Hz resolution; this ensures fast response and measurement updates, especially at the lower resolutions.

Relative measurements can be made in which the frequency is measured as a difference from a reference measurement made earlier. This allows very small changes such as frequency drift to be conveniently measured. A frequency offset facility is also available in which frequency values to 1 Hz resolution can be added or subtracted as fixed offsets to an applied signal.

The frequency to be measured can be compared with pass/fail frequency limits specified by the user. The result of the comparison is displayed on the front panel, and an audio alarm is given for out of limits frequencies.

## Power measurements

The CPM can be used to measure RF and microwave power from -65 dBm (1 nW) to +44 dBm (25 W) over a wide range of frequencies using the IFR 6910, 6920 and 6930 series of power sensors. Refer to 'Supported power sensors' later in this chapter for the frequency and power ranges covered by each sensor.

High accuracy is achieved by applying calibration and linearity factor correction. All power sensors are supplied with individual calibration data. The 6900 series sensors all have an excellent return loss specification to minimise mismatch errors in power measurement. The sensors are provided with a self-identification mechanism which enables the instrument to determine the sensor type and hence the corrections to apply.

Precise power measurements are ensured by calibrating the sensor using the integral 0 dBm (1 mW), 50 MHz power reference (traceable to National Standards), and by entering calibration and linearity factors that are unique to each sensor.

The instrument is fully auto-ranging and power levels are displayed to four digits resolution in units of either dBm, Watts or dBW. An analogue peaking meter is provided in addition to the four digit display for convenient monitoring of power fluctuations with time, and to assist in peaking and tuning.

Limit checking with both upper and lower power limits may be performed, with convenient audio and visual alarms to alert the user of a measurement that is out of limits.

A power offset in dB can be applied to the measurement to allow for the attenuation or amplification of power. Power measurements can also be made relative to a selected power level.

For pulsed signals, direct readings of peak pulse power can be calculated by applying the appropriate duty cycle correction.

## **Other features**

The CPM features a built-in DVM to allow voltage measurements to be made in the range 0 to 10 V; the peaking meter also functions in this mode. This feature is specifically for measurements of radio link automatic gain control voltages.

When the instrument is switched off, the current settings are saved in non-volatile memory, so that the instrument will be in the same state when it is next powered up.

The large 320 × 240 pixel liquid crystal display shows simultaneous power and frequency readings, together with other information relating to the measurements. The lower part of the display is used for the soft keys that are used to set up the instrument and select functions. The LCD has an integral backlight for use in low light conditions, and the display contrast can be adjusted for the best viewing conditions.

The supplied AC adapter is used to recharge the internal batteries via the rear panel DC input, but can also be used for powering the unit for bench applications. The vehicle DC supply lead provided with the instrument enables it to be charged from a standard vehicle 12 V supply. New fully charged batteries will provide a minimum of 3 hours continuous use before recharging is required, reducing with extensive use, high temperature and high humidity. The battery state is continuously monitored, and the display shows the percentage of battery life remaining. In addition, a front panel warning is given when the batteries require recharging (less than 25% full charge). As well as being charged within the instrument, the battery pack can be easily removed from the instrument and recharged using the optional desktop battery charger; operation of the CPM can continue using a spare battery pack.

The CPM has an auto power-off feature that can be enabled during battery operation, whereby it powers down automatically if there have been no keypresses for 10 or 30 minutes (selectable by the user).

## Performance data

**Note**

All 'typical' specifications are non-warranted.

### Frequency measurements

**Frequency range**

CPM 20	10 MHz to 20 GHz
CPM 46	10 MHz to 46 GHz

**Sensitivity**

10 MHz to 20 GHz	-20 dBm (typical below 20 MHz)
20 GHz to 26.5 GHz	-20 dBm
26.5 GHz to 40 GHz	-15 dBm
40 GHz to 46 GHz	-10 dBm

**Accuracy**

(At 1 Hz resolution)

10 MHz to 20 GHz	Frequency standard error $\pm 25$ Hz.
20 GHz to 46 GHz	Frequency standard error $\pm 50$ Hz.

**Input connector**

CPM 20	Type N female
CPM 46	2.92 mm female

**Input impedance**

50  $\Omega$  nominal

**Maximum input**

+10 dBm (typical below 20 MHz)

**Damage level**

+27 dBm

**Resolution**

User selectable 1 Hz to 1 MHz.

**Measurement time**

1 Hz resolution	<2 s
>1 Hz resolution	<250 ms

**Tracking**

30 MHz/s

**FM tolerance**

20 MHz peak to peak, for >1 kHz rate.

**AM tolerance** Any index as long as minimum level does not fall below sensitivity (20 kHz rate).

**Amplitude discrimination** 20 dB for signals >400 MHz

**Frequency standard**

Temperature stability

DTCXO (standard)

Better than  $\pm 5$  in  $10^8$ , 0 to 50°C

TCXO (option 001)

Better than  $\pm 1$  in  $10^6$ , 0 to 50°C

Ageing

DTCXO (standard)

$\pm 0.3$  ppm / year

TCXO (option 001)

$\pm 1$  ppm / year

External frequency standard input

10 MHz, 0.7 to 5 V pk-pk sine or square wave into 1 k $\Omega$  nominal. AC coupled. BNC female.

**Features**

Limit checking

The frequency measurement can be compared with user-defined upper and lower limits and a pass/fail indication is shown on the display.

Relative frequency measurements

Enables the current measurement value to be used as an offset for relative frequency measurements.

Frequency offset

Enables a user-defined frequency value to be added or subtracted from the measurement before being displayed.

Frequency hold

Enables the frequency readout to be frozen.

**Power measurements**

**Frequency range**

30 kHz to 46 GHz (dependent on sensor).

**Power range**

-65 dBm (316 pW) to +44 dBm (25 W)  
(dependent on sensor)

<b>Power sensors supported</b>	6910 series (-30 to +20 dBm) 6920 series(-65 to -20 dBm) 6930 series (-15 to +35 dBm) 6930 series option 002 (-5 to +44 dBm)  <b>Note:</b> When used with CPM, 6923 and 6924 power sensors are usable down to -60 dBm.
<b>Power accuracy</b> (after calibration using a 0 dBm power reference)	$\pm 0.2$ dB after calibration using the 0 dBm power reference.  Specification applies when measuring a signal in the centre of the power sensor dynamic range, from a source with return loss better than 14 dB.
Resolution	4 digits
Units	dBm, dBW, nW, $\mu$ W, mW, W, kW.
<b>Correction</b>	
Linearity Factor	Ability to enter in range 0.01 to 15 with 0.01 resolution. Defaults to standard setting.
Calibration Factor	Ability to enter in range 0.01% to 200%. Resolution: 0.01 up to 99.99% 0.1 above 100%
Auto-calibration	Ability to calibrate against a 0 dBm (1 mW) 50 MHz power reference.
Auto-zero	Removes DC offset from amplifier gain stages and power sensor.
<b>Noise floor</b> (after auto-zero)	
6910 series	< -30 dBm
6920 series	< -65 dBm -65 dBm (-60 dBm for 6923 and 6924)
6930 series	< -15 dBm
<b>Facilities</b>	
Peaking meter	Presents the power measurement in analogue form.

Limit checking.	The power measurement can be compared with user-defined upper and lower limits and a pass/fail indication is shown on the display.  An audible tone is produced when the measured power is above or below the programmed limits.
Relative power measurements	Enables the current measurement value to be used as an offset for relative power measurements.
Power offset	Enables a user-defined value in dB to be added or subtracted from the measurement before being displayed.
Duty cycle correction	Enables entry of duty cycle of pulsed signal in the range 0.001% to 100%. The instrument calculates the peak value of the pulsed signal from the average power measured by the sensor.

**Power reference**

Frequency	50 MHz $\pm$ 0.10 MHz
Power level	0 dBm (1 mW)
Uncertainty	$\pm$ 0.7% traceable to National Standards.
Accuracy	$\pm$ 1.2% worst case for one year.
Output connector	N (female) 50 $\Omega$ . Adapters are supplied with 75 $\Omega$ , 3.5 mm and 2.92 mm power sensors.

**Digital voltmeter**

<b>Range</b>	0 to +10 V DC (protected to 40 V).
<b>Accuracy</b>	$\pm$ 2.5% of reading
<b>Resolution</b>	10 mV
<b>Input impedance</b>	6 M $\Omega$ in parallel with 100 pF.
<b>Connector</b>	4 mm banana sockets.  Negative socket connected to chassis via 10 M $\Omega$ .

**General**

<b>Display</b>	LCD, transfective type, 320 $\times$ 240 pixels, with backlight.
----------------	--

<b>Non-volatile memory</b>	The instrument settings at switch off are automatically stored in non-volatile memory; at power up they are restored unchanged.
<b>Automatic power off</b>	When the instrument is powered from the internal batteries, the auto power off feature can be enabled, whereby power to the instrument is turned off after 10 or 30 minutes without any keyboard commands.
<b>Terminal interface</b>	
Connector	9 pin D-type male. RS-232 (DTE) compatible.
<b>Power requirements</b>	
Rechargeable battery	Type DR35S, as supplied. 3 hours continuous operation minimum.
Recharge time	<4 hours
Battery life indication	The display shows the percentage battery life remaining. In addition, a front panel LED indicates <25% of battery charge remaining.
DC input (vehicle supply or mains adapter)	10 V to 28 V, 32 VA max. 2.1 mm power connector
<b>Safety</b>	
Instrument	Complies with the following standards for class III portable equipment and is for use in a pollution degree 2 environment.  EN61010-1    UL3111-1*    IEC1010-1 CAN/CSA-C22.2 No. 1010.1-92 *  The instrument is designed to operate from an installation category 1 supply.  * Third party approval.

AC power adapter	Complies with the following standards for class II portable equipment and is for use in a pollution degree 2 environment. UL1950* CAN/CSA-C22 No. 234 * EN60950 VDE 0805 * Third party approval.
Input voltage	90 to 264 V AC.
Frequency	47 to 63 Hz.
Output voltage	18 V DC, $\pm 5\%$ regulation, 180 mV pk-pk ripple.
Maximum load	2.5 A.

**Electromagnetic compatibility**

Instrument	Conforms to the protection requirements of the EEC Council Directive 89/336/EEC. Complies with the limits specified in the following standards: Emissions: EN55011:1991 AS/NZS2064.1/2 CISPR 11  Immunity EN50082-1:1992 AS/NZS4252.1 IEC801-2:1991 IEC801-3:1984 IEC801-4:1988
AC power adapter	Complies with the limits specified in the following standards: Emissions: FCC 20780, part 15, class B EN55022, class B VDE 0878, part 3, class N  Immunity: IEC1000-4-2:1991 IEC1000-4-3:1984 IEC1000-4-4:1988

## GENERAL INFORMATION

---

### Rated range of use

Temperature	
Battery operation	0°C to +45°C
AC adapter operation	0°C to +40°C
Humidity	Up to 93% RH at +40°C
Altitude	2000 m (at up to 80% RH)

### Conditions of storage and transport

Temperature	
Instrument	-40°C to +70°C
Battery	-20°C to +35°C (1 year), -20°C to +50°C (2 weeks)
AC adapter	-10°C to +70°C
Humidity	Up to 93% RH at +40°C
Altitude	Up to 4750 m

### Shock and vibration

MIL-T-28800 for class 3

### Drop test

IEC 68-2-32

### Overall instrument protection

IEC 529 (rating IP 523)

### Dimensions and weight

Width	285 mm (11.2 in)
Height	130 mm (5.1 in)
Depth	210 mm (8.3 in)
Weight	4.9 kg (10.8 lb) including battery
	5.4 kg (11.9 lb) including battery and accessory pouch

## Versions and accessories

### Versions

CPM 20	10 MHz to 20 GHz
CPM 46	10 MHz to 46 GHz

### Options

Option 001	TCXO replaces the DTCXO of the standard version.
------------	--

### Supplied accessories

41690-616	Accessory pouch
41700-788	Carrying strap
23725-151	Rechargeable battery
28541-213	Universal AC adapter / battery charger
	Power lead for charger (see Chapter 2)
43169-039	Vehicle DC supply lead
23443-874	BNC adapter for DVM
43138-663	1.5 m power sensor cable
46882-335	Operating Manual

### Optional accessories

54311-219	20 GHz standard counter cable, 1.5 m, SMA(m) to SMA(m)
54351-027	40 GHz counter cable, 0.5 m, 2.92 mm (m) to 2.92 mm (m)
54311-134	Adapter N (m) to SMA (f)
43113-022	Spare battery
54464-001	Desktop battery charger
46880-084	Service Manual
	6900 Series power sensors (see below)

## Supported power sensors

The Counter Power Meter supports the full range of IFR power sensors. Seventeen sensors are available, covering the frequency range from 30 kHz to 46 GHz (dependent upon sensor used). The power range depends on sensor type, and covers from -60 dBm (1 nW) to +44 dBm (25 W).

To cater for the different frequency ranges, connector types include N type, 3.5 mm and 2.92 mm.

The following table summarises the characteristics of the power sensors currently available for use with the Counter Power Meter.

**General characteristics of 6910, 6920 and 6930 series power sensors  
when used with the CPM 20 and CPM 46**

Sensor	Frequency range	Power range	Connector
6910	10 MHz to 20 GHz	-30 to +20 dBm	N type (m)
6911	10 MHz to 20 GHz	-30 to +20 dBm	APC 7
6912	30 kHz to 4.2 GHz	-30 to +20 dBm	N type (m)
6913	10 MHz to 26.5 GHz	-30 to +20 dBm	3.5 mm (m)
6914	10 MHz to 40 GHz	-30 to +20 dBm	PC 2.92 mm (m)
6914S	10 MHz to 46 GHz	-30 to +20 dBm	PC 2.92 mm (m)
6919	30 kHz to 3 GHz	-30 to +20 dBm	N type 75 ohm
6920	10 MHz to 20 GHz	-65 to -20 dBm	N type (m)
6923	10 MHz to 26.5 GHz	-60 to -20 dBm	3.5 mm (m)
6924	10 MHz to 40 GHz	-60 to -20 dBm	PC 2.92 mm (m)
6924S	10 MHz to 46 GHz	-60 to -20 dBm	PC 2.92 mm (m)
6930	10 MHz to 18 GHz	-15 to +35 dBm	N type (m)
6930-002	10 MHz to 18 GHz	-5 to +44 dBm	N type (m)
6932	30 kHz to 4.2 GHz	-15 to +35 dBm	N type (m)
6932-002	30 kHz to 4.2 GHz	-5 to +44 dBm	N type (m)
6934	10 MHz to 40 GHz	-15 to +30 dBm	PC 2.92 mm (m)
6934S	10 MHz to 46 GHz	-15 to +30 dBm	PC 2.92 mm (m)

The maximum safe input power for the power sensors is as follows:

6910 series:	+25 dBm (300 mW) continuous, +42 dBm (15 W) for 2 $\mu$ s.
6920 series:	+26 dBm (400 mW) continuous, +30 dBm (1 W) for 2 $\mu$ s.
6930, 6932	+37 dBm (5W) continuous, +50 dBm (100 W) for 2 $\mu$ s.
6930-002, 6932-002	45 dBm (30 W) continuous, 60 dBm (1 kW) for 2 $\mu$ s.
6934	+33 dBm (2W) continuous, +45 dBm (32 W) for 2 $\mu$ s.

Full details on the characteristics, operation and maintenance of the sensors are contained in the instruction manual which accompanies each sensor.

## EC Declaration of Conformity

**Certificate Ref. No.**

**EEA00026**

The undersigned, representing:

Manufacturer:	<b>IFR Ltd.</b>
Address:	<b>Longacres House, Norton Green Road, Stevenage, Hertfordshire, U. K. SG1 2BA</b>

Herewith declares that the product:

Equipment Description:	Counter Power Meter (including Power Supply 28541-231Y)
Model No.	CPM 20 and CPM 46
Options:	001

is in conformity with the following EC directive(s)  
(including all applicable amendments)

Reference No.	Title:
73/23/EEC	Low Voltage Directive
89/336/EEC	EMC Directive

and that the standards and/or technical specifications referenced below have been applied:

Safety:	EMC:	
IEC/EN61010-1	EN55011:1991 Class B	
	EN50082-1:1992	
	EN60555-2:1987	

IFR Stevenage \_\_\_\_\_ (Place)

22nd June 1998 \_\_\_\_\_ (Date)

*Alan Smithies.*

\_\_\_\_\_  
(Signature)

Alan Smithies - Product Liability Manager

---

## Chapter 2

# INSTALLATION

### Contents

Power requirements.....	2-1
Removal of the battery for charging.....	2-5
Removal of the accessory pouch.....	2-5
Goods-in checks.....	2-6
Routine maintenance.....	2-6

### **WARNING** Initial visual inspection

After unpacking the instrument, inspect the shipping container and its cushioning material for signs of stress or damage. If damage is identified, retain the packing material for examination by the carrier in the event that a claim is made.

Examine the instrument for signs of damage; do not connect the instrument to a supply when damage is present, internal electrical damage could result in shock if the instrument is turned on.

### Power requirements

The CPM is fitted with a rechargeable battery pack which is sufficient for up to 3 hours continuous use between charges when new. A 2.1 mm input connector is provided for a DC supply input of 10 V to 28 V.

The supplied AC adapter can be used to both charge the internal batteries and power the unit for bench applications.

The supplied vehicle DC supply lead enables the unit to be charged from a standard vehicle cigar lighter socket.

### **Note**

**If the optional DC supply lead needs to be replaced, it must be fitted with a 5 A quick-blow fuse.**

A recharge time of 4 hours is recommended for a full charge. It should be noted that both the CPM and the optional desktop battery charger can sense when the battery is fully charged and will terminate the charging process. This means that the battery can be left on charge for extended periods without affecting its performance.

The power LED adjacent to the on/off switch illuminates when the unit is powered externally. This LED flashes when the batteries require charging (i.e. when the battery charge drops to 25% of full capacity). In addition, there is a permanent indication on the display of the percentage battery life remaining.

## Notes on the internal battery

- (a) At normal temperatures (20°C) a charged battery will lose 30% of its charge in one month, due to self discharge. At higher temperatures the self discharge rate will be higher. This means that the battery can become discharged through a long period of non-use (this situation can therefore occur with a new unit).
- (b) Ideally the battery should be stored between 10°C and 30°C to retain normal performance. Operation of the instrument between 0°C to 10°C and between 30°C to 45°C will show reduced capacity and reduced storage time.
- (c) The battery should be capable of 500 charge/discharge cycles and still be providing 80% of its original performance.
- (d) If the battery is not fully discharged each time it is placed on charge, then eventually there will be a deterioration in performance; this will be seen as a reduction in capacity from full charge. However, the battery can be restored to full capacity by exercising it with a few full discharge/recharge cycles.
- (e) If the CPM has not been powered from an external DC supply or the battery has not been used for an extended period of time, then the battery may become fully discharged. Under such circumstances the CPM may not recognise the presence of the battery. It will show 'NONE' in the battery life area of the display. To recover the battery to its normal operating condition the following procedure must be followed:
  - (1) Connect the AC adapter to the CPM.
  - (2) Turn on the CPM.
  - (3) Wait approximately 20 minutes, during which time the battery life indicator will display 'NONE'.

After approximately 20 minutes the battery will have recovered to a minimum indicated charge state (0%). The CPM will now automatically switch to fast charge mode and will fully charge the battery.

<b>Note</b>
-------------

Before using the instrument for the first time it may be necessary to place the battery on charge.

<b>CAUTION</b>
----------------

## Class I power cords (3-core)

### General

When the equipment has to be plugged into a Class II (ungrounded) 2-terminal socket outlet, the cable should either be fitted with a 3-pin Class I plug and used in conjunction with an adapter incorporating a ground wire, or be fitted with a Class II plug with an integral ground wire. The ground wire must be securely fastened to ground. Grounding one terminal on a 2-terminal socket will not provide adequate protection.

In the event that a moulded plug has to be removed from a lead, it must be disposed of immediately. A plug with bare flexible cords is hazardous if engaged in a live socket outlet.

Power cords with the following terminations are available from IFR Ltd. Please check with your local sales office for availability.

This equipment is provided with a 3-wire (grounded) cordset which includes a moulded IEC 320 connector for connection to the equipment. The cable must be fitted with an approved plug which, when plugged into an appropriate 3-terminal socket outlet, grounds the case of the equipment. Failure to ground the equipment may expose the operator to hazardous voltage levels. Depending upon the destination country, the colour coding of the wires will differ:-

**Wire ended**

Country	IEC 320 plug type	IFR part number
Universal	Straight through	23424-158
Universal	Right angled	23424-159

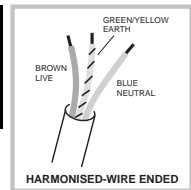

**North America**

**Harmonised**

Line (Live)	Black	Brown
Neutral	White	Blue
Ground (Earth)	Green	Green/Yellow

**British**

Country	IEC 320 plug type	IFR part number
United Kingdom	Straight through	23422-001
United Kingdom	Right angled	23422-002

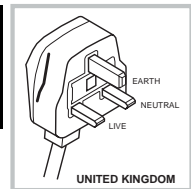

The UK lead is fitted with an ASTA approved moulded plug to BS 1363.

A replaceable 13 A fuse to BS 1362 is contained within the plug. This fuse is only designed to protect the lead assembly. Never use the plug with the detachable fuse cover omitted or if the cover is damaged.

The fuse(s) or circuit breaker to protect the equipment is fitted at the back of the equipment.

**North American**

Country	IEC 320 plug type	IFR part number
North American	Straight through	23422-004
North American	Right angled	23422-005

The North American lead is fitted with a NEMA 5-15P (Canadian CS22.2 No 42) plug and carries approvals from UL and CSA for use in the USA and Canada.

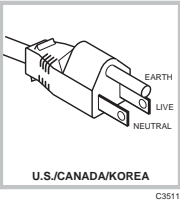

**Continental Europe**

Country	IEC 320 plug type	IFR part number
Europe	Straight through	23422-006
Europe	Right angled	23422-007

The Continental European lead is fitted with a right angle IEC83 standard C4 plug (CEE 7/7) which allows it to be used in sockets with either a male earth pin (standard C 3b) or side earth clips (standard C 2b) the latter is commonly called the German ‘Schuko’ plug. In common with other Schuko style plugs, the plug is not polarized when fitted into a Schuko socket. The lead carries approvals for use in Austria, Belgium, Finland, France, Germany, Holland, Italy, Norway and Sweden. Note that this plug will not fit Italian standard CEI 23-16 outlets. The lead should not be used in Denmark given that the earth connection will not be made.

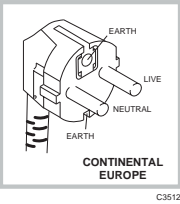

**Français**

Le câble d'alimentation d'Europe Continentale est muni d'un connecteur mâle à angle droit type CEI83, standard C4 (CEE 7/7), qui peut être utilisé dans une prise femelle à ergot de terre (standard C 3b) ou à clips latéraux (standard C 2b), cette dernière étant communément appelée prise "Schuko" allemande. De la même façon que les autres connecteurs de type Schuko, celui-ci n'est pas polarisé lorsqu'il s'adapte à une prise femelle Schuko. Ce câble d'alimentation est homologué en Allemagne, Autriche, Belgique, Finlande, France, Hollande, Italie, Norvège et Suède. A noter que ce connecteur n'est pas compatible avec les prises de courant italiennes au standard CEI 23-16. Ce câble ne doit pas être utilisé au Danemark à cause du défaut de connexion de masse.

**Deutsch**

Das kontinentaleuropäische Netzkabel ist mit einem rechtwinkeligen Stecker nach IEC83 C4 (CEE7/7) Standard versehen, welcher sowohl in Steckdosen mit Erde-Stift (Standard C 3b) oder seitlichen Erdeklemmen, im allgemeinen "Schukosteckdose" genannt, paßt. Üblicherweise ist der Schukostecker bei Verwendung in Schukosteckdosen nicht gepolt. Dieses Netzkabel besitzt Zulassung für Österreich, Belgien, Finnland, Frankreich, Deutschland, Holland, Italien, Norwegen und Schweden.

Hinweis: Dieser Schukostecker paßt nicht in die italienischen Standardsteckdosen nach CEI 23-16 Norm. Dieses Netzkabel sollte nicht in Dänemark verwendet werden, da hier keine Erdeverbindung hergestellt wird.

### Español

El cable de alimentación tipo Europeo Continental dispone de una clavija C4 normalizada IEC83 (CEE 7/7) que permite su utilización tanto en bases de enchufe con toma de tierra macho (tipo C 3b) o con toma de tierra mediante contactos laterales (tipo C 2b) que, en este último caso, suele denominarse "Schuko". Al igual que cualquier otra clavija tipo Schuko, las conexiones a red no están polarizadas cuando se conectan a una base tipo Schuko. El cable lleva autorización para su uso en Austria, Bélgica, Finlandia, Francia, Alemania, Holanda, Italia, Noruega y Suecia. Observe que este cable no se adapta a la norma italiana CEI 23-16. El cable no debe utilizarse en Dinamarca en el caso de no efectuarse conexión a tierra.

### Italiano

I cavi d'alimentazione per l'Europa continentale vengono forniti terminati con una spina ad angolo retto del tipo C4 secondo lo standard IEC83 (CEE 7/7) che può essere usato in prese in cui la terra può essere fornita o tramite connettore maschio (C 3b) o tramite clips laterali (C 2b), quest'ultima comunemente detta di tipo tedesca "Schuko". Questa spina, quando collegata ad una presa Schuko, non è polarizzata.

Il cavo può essere usato in Austria, Belgio, Finlandia, Francia, Germania, Olanda, Norvegia, Svezia ed Italia. E' da notare che per l'Italia questo non risponde allo standard CEI 23-16.

Questa spina non dovrebbe invece essere usata in Danimarca in quanto non realizza il collegamento di terra.

## Removal of the battery for charging

The internal battery can be removed for charging outside of the instrument, and a spare battery can be fitted so that battery operation can continue. Access to the battery is via a removable panel at the rear of the instrument. The battery is removed by pulling it away from the connector and lifting it out.

The battery is charged using the optional desktop charger; a flat battery will be recharged in approximately 4 hours. The battery has a built-in indicator that shows its charge state; it is activated by pressing the adjacent button..

## Removal of the accessory pouch

The fasteners that secure the accessory pouch to the top of the instrument are not the usual push on / pull off type. To separate the fasteners insert a finger under the pouch behind the fastener and pull diagonally outwards (as shown in the diagram) then upwards.

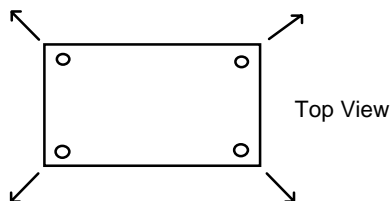

### **Goods-in checks**

Refer to Chapter 5, 'Acceptance testing'.

### **Routine maintenance**

#### **Cleaning**

Before commencing any cleaning, switch off the instrument and disconnect from the supply. The exterior surface of the case and the LCD should be cleaned with a soft cloth moistened with water. No other cleaning agents should be used.

---

# Chapter 3

## OPERATION

### Contents

Introduction.....	3-2
Front panel features.....	3-2
Rear panel features.....	3-4
Front panel keys and display.....	3-5
Data entry.....	3-7
Soft key menus.....	3-9
Counter.....	3-9
Power Meter.....	3-11
Units.....	3-14
Sensor Cal.....	3-15
DVM.....	3-16
Peaking Meter.....	3-17
Utility.....	3-18
Switching on.....	3-20
Making frequency measurements.....	3-20
Using the counter features.....	3-20
Frequency resolution.....	3-20
Limit checking.....	3-21
Relative and offset measurements.....	3-21
Making power measurements.....	3-22
Sensor correction and calibration.....	3-22
Measurement procedure.....	3-22
Using the power meter features.....	3-23
Peaking meter.....	3-23
Limit checking.....	3-24
dB relative and offset measurements.....	3-24
Duty cycle correction.....	3-25
Averaging.....	3-25
Sensor overload warnings.....	3-26
Low level power measurements.....	3-26
Voltage measurements.....	3-26
Power-down instrument settings.....	3-27

### List of figures

Fig. 3-1 Front panel.....	3-2
Fig. 3-2 Rear panel.....	3-4
Fig. 3-3 Display features.....	3-6

## Introduction

This chapter explains how to operate the Counter Power Meter using the front panel keys and soft key menus. It provides descriptions of the front and rear panel features and describes the information that is displayed on the LCD.

The following conventions are used in this chapter:

**CAPS** Capitals are used to identify panel markings, or system functions where no direct reference to an associated key is intended.

**[CAPS]** Capitals in square brackets indicate hard key titles.

*[Italics]* Italics in square brackets indicate soft key titles.

*[Hold ■]* A '■' after a soft key title indicates that the key has a toggle action, and that the function is enabled.

*[Hold □]* A '□' after a soft key title indicates that the key has a toggle action, and that the function is disabled.

## Front panel features

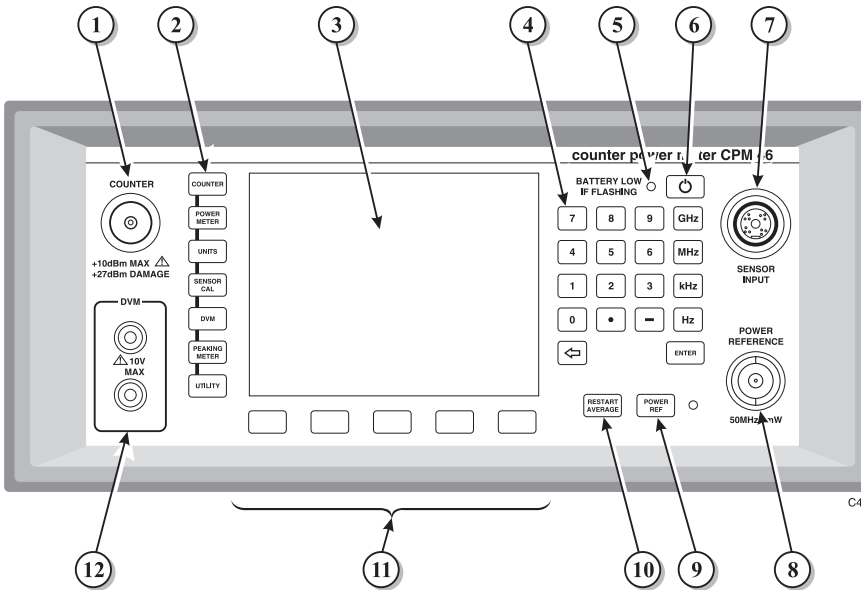
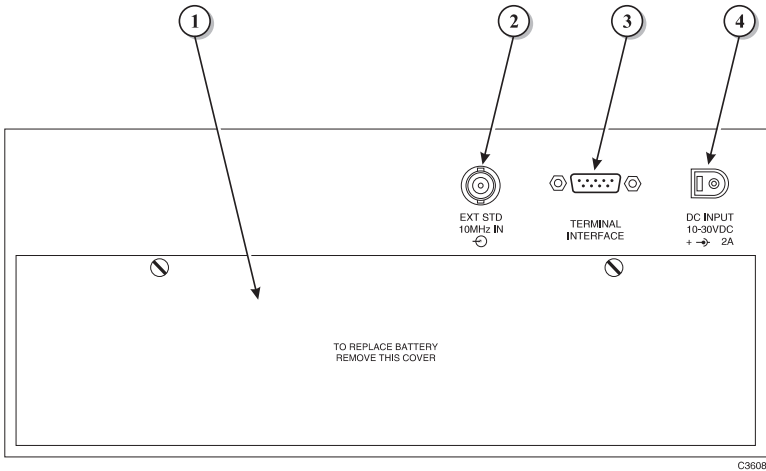

Fig. 3-1 Front panel

- 1 **COUNTER connector.** This input is used when measuring the frequency of a signal.
- 2 **Function keys.** These keys are used to access the soft key menus for setting up the instrument to measure frequency and power, and to control various system functions.
- 3 **Display.** The LCD is used to display the frequency and power measurements, together with other information relating to the measurements, and to display soft key labels.
- 4 **Numeric entry and terminator keys.** These keys are used for entering values of numeric parameters.
- 5 **Power On / Battery Low indicator.** This is an LED that is illuminated when the instrument is powered, either from the internal batteries or from the AC adapter. The LED flashes when the battery charge is low (< 25% of full capacity).
- 6 **Power On/Off.** Activates/de-activates the instrument.
- 7 **SENSOR INPUT connector.** Accepts multipin connector from the supplied power sensor cable.
- 8 **POWER REFERENCE connector.** Provides a 50 MHz, 1 mW reference signal that is used to calibrate power sensors before taking any measurements.
- 9 **POWER REF key.** Switches the internal power reference on and off. In order to conserve battery power, the power reference will switch off automatically after a two minute time-out period. The LED adjacent to the key is illuminated when the power reference is on.
- 10 **RESTART AVERAGE key.** Used to restart the averaging process, which is used to reduce the effects of noise on a power measurement.
- 11 **Soft keys.** The five soft keys are used to select the desired control and functional options presented by the various menus accessed through the function keys to the left of the display.
- 12 **DVM terminals.** These are 4 mm banana sockets that are used when making DC voltage measurements (10 V maximum).

## Rear panel features



*Fig. 3-2 Rear panel*

- 1 Battery cover.** Removal of this cover provides access to the internal rechargeable battery pack.
- 2 EXT 10 MHz connector.** This is a BNC connector that accepts a 10 MHz input from an external frequency standard (0.7 to 5 V peak-to-peak sine or square wave).
- 3 RS-232 connector.** This is a 9 way D-type connector that allows connection to a controller/modem for remote operation of the instrument.
- 4 EXT DC INPUT connector.** Accepts a DC input in the range 10 to 28 V from either the supplied AC adapter or a vehicle 12 V supply.

## Front panel keys and display

Seven front panel keys to the left of the display provide access to the instrument functions via soft key menus. Each key has an adjacent LED which lights up when the function is active. The menu display related functions or choices for a particular function, with each choice corresponding to one of the five soft keys located below the display. Pressing one of the soft keys either executes the labelled function and makes it the active function, or changes the current status of a function, or presents another set of menu labels. The type of action is indicated by the shape of the box enclosing the soft key label, as shown below:



Indicates that selecting the soft key will immediately cause the instrument to perform the designated function, without any further interaction from the user. The box contains a representation of an indicator lamp which 'lights up' to indicate that the function is on.



Indicates that a data entry field will be displayed, in addition to any soft keys, which enables a parameter to be changed for the function. Depending on the function either one or two data entry fields will be displayed. The box contains a representation of an indicator lamp which 'lights up' to indicate that the function is on.



Two or more boxes linked by a horizontal bar indicate a group of related items of which one may be selected. The currently selected item is highlighted; pressing it will have no effect, but selecting another of the same group will deselect it.

In addition, there are two dedicated keys (**[RESTART AVERAGE]** and **[POWER REF]**), that are used to restart power meter averaging and to turn the internal power reference on and off.

The liquid crystal display is divided into frequency readout, power readout and soft key display areas. Various annunciators are displayed above the readouts that indicate the status of related functions. See Fig. 3-3.

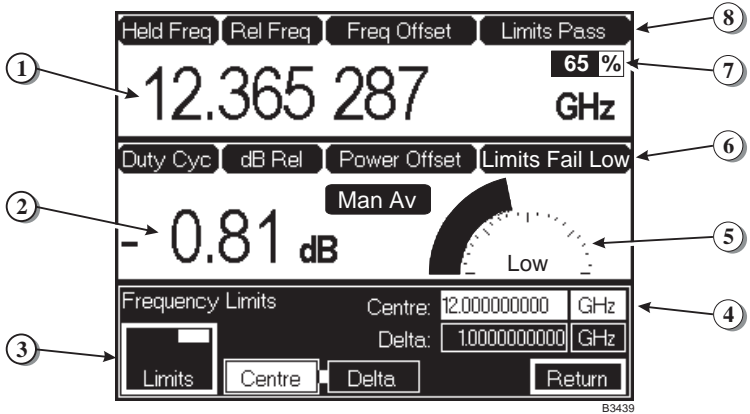

Fig. 3-3 Display features

- 1 **Frequency readout.** The number of digits displayed is in accordance with the currently specified frequency resolution (see Counter Resolution menu). The digits are grouped into threes to improve readability, and the units are Hz, kHz, MHz or GHz as appropriate.
  
- 2 **Power readout.** This is displayed to four digits. The units can be either logarithmic (dB(m), dBW) or linear (nW,  $\mu$ W, mW, W, kW). The instrument selects the linear units appropriate to the measurement. In DVM mode the readout is used to display the voltage at the DVM terminals.
  
- 3 **Soft key display area.** The bottom part of the LCD is used to display up to five soft key labels. During sensor zeroing and calibration the soft keys are replaced by a horizontal progress indicator bar.
  
- 4 **Data entry box.** Where applicable, data entry boxes are displayed to enable parameter values to be changed.
  
- 5 **Peaking indicator.** A peaking indicator is provided to the right of the power readout. This is a graphical representation of a meter which provides an analogue indication of power level. In DVM mode the peaking meter is used to display the voltage at the DVM terminals

**6 Power meter annunciators.**

<b>Duty Cycle</b>	Indicates that duty cycle correction is being applied to the measurement.
<b>dB Rel</b>	Indicates that relative power measurements are enabled.
<b>Power Offset</b>	Indicates that a dB offset is being applied to the measurement.
<b>Limits Pass / Limits Fail Low / Limits Fail Hi</b>	Indicates the pass/fail status of the limit checking function.
<b>Man Av</b>	Indicates that the automatic restart averaging function has been disabled, and that restart averaging is now under manual control, using the <b>[RESTART AVERAGE]</b> key.

**7 Battery life indication.** Shows the percentage of battery life remaining.

**8 Frequency counter annunciators.**

<b>Held Freq</b>	Indicates that frequency readout has been frozen.
<b>Rel Freq</b>	Indicates that relative frequency measurements are enabled.
<b>Freq Offset</b>	Indicates that a frequency offset is being applied to the measurement.
<b>Limits Pass / Limits Fail Low / Limits Fail Hi</b>	Indicates the pass/fail status of the limit checking function.

**Data entry**

The data entry keypad is used to modify parameter values. A data entry field is displayed containing the current value of the parameter. If two fields are displayed, the required field is made active by pressing the appropriate soft key. The entire field is erased when the first digit of the new data is entered. For

negative numbers the minus key must be pressed first (the minus key is ignored when parameters can only take positive values). The backspace key [←] deletes the last digit entered from the keypad.

In the case of frequency entry, the units multiplier is selected by pressing one of the four terminator keys to the right of the numeric keys. Where the units are not selectable or a unitless entry is required (e.g. Linearity Factor), the [ENTER] key is used to terminate the entry. In cases where a single value is associated with a function, it is automatically enabled on termination of the entry. This also applies to the second value of a pair of numeric entries (e.g. for limit checking).

If a numeric value outside the permitted range of the parameter is entered, the entry will be clipped to the nearest permitted value.

If the [*Return*] soft key is pressed the system returns to the previous menu. If data entry is in progress but has not yet been terminated the previous value will be retained.

## Soft key menus

### Counter

This menu is accessed by pressing the [COUNTER] key and enables the resolution of the frequency readout to be set, enables relative and offset measurements to be made, and provides a limit checking function.

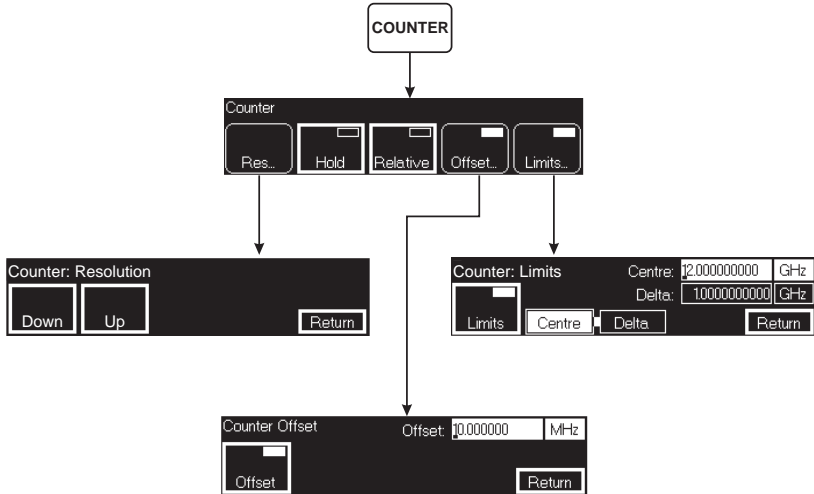

B3444

- Res...** Leads to a sub-menu which is used to select the resolution to which the frequency readout is displayed. The resolution can be set between 1 Hz and 1 MHz in decade steps, using the [Down] and [Up] soft keys. The default setting is 1 kHz.
- Hold** Toggles the *Hold* function on and off. When selected the frequency readout is immediately frozen, and **Held Freq** is displayed above the readout.
- Relative** Toggles relative frequency measurements on and off. When enabled, the current frequency is stored and subtracted from all subsequent measurements. **Rel Freq** is displayed above the readout to indicate that the relative frequency mode is active.
- Offset...** Leads to a sub-menu which enables a frequency offset to be specified and applied to the measurement. Frequency offsets to 1 Hz resolution, either positive or negative, can be added to the input signal.

A data entry box is displayed so that the current offset value can be changed. If **[Return]** is pressed before the value has been terminated, the previous value is retained on exit.

The **[Offset]** soft key toggles the offset function on and off. When enabled, **Freq Offset** is displayed above the readout.

### Limits...

Leads to a sub-menu which enables a limit checking function to be implemented, allowing the input frequency to be compared against upper and lower frequency limits defined by the user. The result of the comparison is displayed above the readout, i.e. whether the result is within limits (**Limits Pass**), or whether the upper or lower limit has been exceeded (**Limits Fail Hi** or **Limits Fail Low**). The beeper will sound if the input frequency fails the limits test.

Frequency limits are entered as a **Centre** (i.e. nominal) frequency and a **Delta** (offset) value (e.g. 10 GHz  $\pm$ 50 MHz). The current values are shown in the data entry box.

The following soft keys are displayed:

**Limits** Toggles the Limits function on and off. When enabled, the limits indicator is displayed above the readout.

**Centre** Selects the Centre frequency for editing. When a terminator key is pressed, the Delta field is selected for editing.

**Delta** Selects the Delta (offset) frequency for editing. When a terminator key is pressed, the Centre field is selected for editing.

**Return** Returns to the Counter top level. If data entry is in progress but has not yet been terminated the previous value will be retained.

## Power Meter

This menu is accessed by pressing the **[POWER METER]** key and enables the Cal Factor to be specified, enables relative and offset measurements to be made, and provides duty cycle correction and limit checking functions.

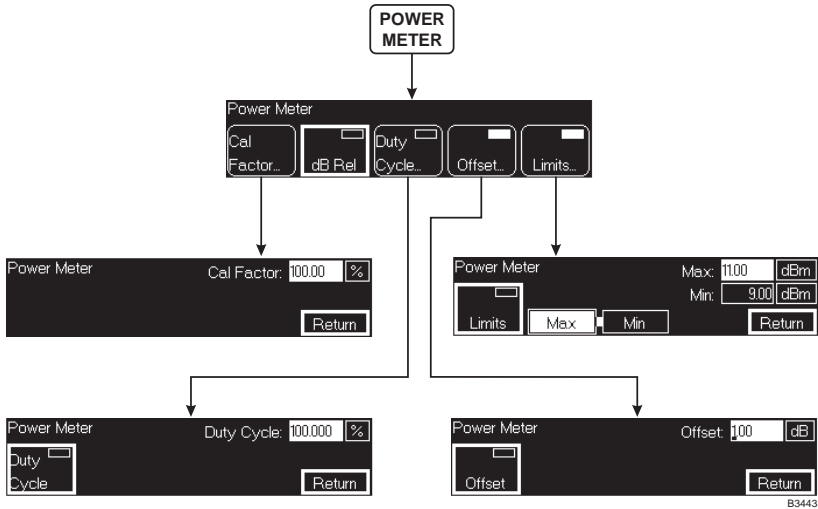

### Cal Factor...

Used to set the Cal Factor corresponding to the frequency of the signal to be measured. A dialogue box is displayed showing the current value of the calibration factor. A new value can be entered if required, in the range 0.01% to 200%.

### dB Rel

Toggles relative power measurements on and off. When this soft key is pressed, the current power reading is made a 0 dB reference. This is achieved by storing the reading and subtracting the value from all subsequent measurements.

**dB Rel** is displayed above the readout to indicate that the relative power mode is active, and the power units are changed to dB. If the dB Relative function is turned off, the display reverts to the units in use when the function was selected. If the power units are changed while dB Relative mode is active, dB Relative mode is turned off.

### **Duty Cycle...**

Allows entry of the duty cycle of a pulsed waveform so that peak pulse power is calculated and displayed.

When this soft key is pressed a sub-menu is presented which enables the duty cycle to be set, in the range 0.001% to 100%.

A data entry box is displayed so that the current duty cycle value can be changed. If **[Return]** is pressed before the value has been terminated, the previous value is retained on exit.

The **[Duty Cycle]** soft key toggles the function on and off. When enabled, **Duty Cycle** is displayed above the readout.

### **Offset...**

Leads to a sub-menu which enables a power offset in dB to be specified and applied to the measurement. Power offsets to 0.01 dB resolution, either positive or negative, can be added to the input signal.

A data entry box is displayed so that the current offset value can be changed. If **[Return]** is pressed before the value has been terminated, the previous value is retained on exit.

The **[Offset]** soft key toggles the offset function on and off. When enabled, **Power Offset** is displayed above the readout.

### **Limits...**

Leads to a sub-menu which enables a limit checking function to be implemented, allowing the input power to be compared against upper and lower power limits defined by the user. The result of the comparison is displayed above the readout, i.e. whether the result is within limits (**Limits Pass**), or whether the upper or lower limit has been exceeded (**Limits Fail Hi** or **Limits Fail Low**). The beeper will sound if the input power fails the limits test. The current limit values are shown in the data entry area, and are entered in dBm. Limit checking operates with any display units.

The following soft keys are displayed:

**Limits** Toggles the Limits function on and off then returns the system to the Power Meter top level. When enabled, the limits indicator is displayed above the readout.

**Max** Selects the Maximum limit value (dBm) for editing. When a terminator key is pressed, the Min field is selected for editing.

**Min** Selects the Minimum limit value (dBm) for editing. When a terminator key is pressed, the Max field is selected for editing.

**Return** Returns to the Power Meter top level. If data entry is in progress but has not yet been terminated the previous value will be retained.

## Units

This menu is accessed by pressing the [UNITS] key and enables the units of the power readout to be specified.

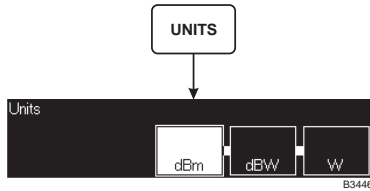

- dBm**                      Selects dB or dBm format. The instrument will automatically select dBm when measuring absolute power, or dB when relative power measurement is enabled.
  
- dBW**                      Selects dBW format.
  
- W**                              Selects Watts format. The appropriate units multiplier is selected automatically; available units are nW,  $\mu$ W, mW, W or kW.

## Sensor Cal

This menu is accessed by pressing the [SENSOR CAL] key and provides facilities for calibrating the power sensor so that accurate power measurements can be made.

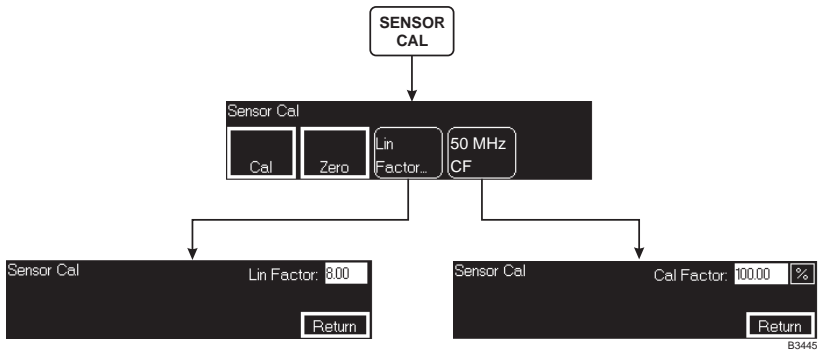

- Cal** Initiates calibration of the sensor against the internal 50 MHz, 1 mW power reference, after displaying a prompt to connect the sensor to the power reference. A sensor zero (see below) is performed automatically prior to the calibration. The progress of the zeroing/calibration is indicated by a horizontal bar shown at the bottom of the display.
- Zero** Initiates sensor zeroing. The sensor can be left connected to the power reference, since it is turned off automatically during this operation. A horizontal bar indicates the progress of the zeroing.
- Lin Factor...** Used to set the linearity factor for the sensor. A dialogue box is displayed showing the current value of linearity factor. A new value can be entered if required, in the range, in the range 0.01 to 15.
- 50 MHz CF...** Used to set the 50 MHz Cal Factor for the sensor. A dialogue box is displayed showing the current value of 50 MHz calibration factor. A new value can be entered if required, in the range 0.01% to 200%.

## DVM

When the **[DVM]** key is pressed, a measurement of the voltage at the DVM terminals replaces the power meter readout. The voltage range that can be displayed is 0 to 10 V DC. The readout is displayed to 4 digits resolution and will be in units of Volts. The peaking meter operates in this mode, and soft keys are provided to set the sensitivity.

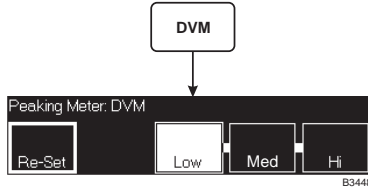

- Re-Set**                 Resets the peaking meter so that the current voltage measurement will give half full scale reading.
- Low**                    Sets the peaking meter sensitivity to  $\pm 5$  V full scale reading with respect to the centre position.
- Med**                    Sets the peaking meter sensitivity to  $\pm 2.5$  V full scale reading with respect to the centre position.
- Hi**                      Sets the peaking meter sensitivity to  $\pm 0.5$  V full scale reading with respect to the centre position.

## Peaking Meter

The peaking meter presents the power measurement in analogue form to facilitate making adjustments. The **[PEAKING METER]** key enables one of three sensitivities to be selected; the setting is shown in the centre of the peaking meter display.

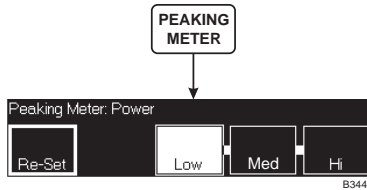

### Re-Set

Resets the peaking meter so that the current power (or voltage) measurement will give half full scale reading. Resetting occurs automatically under the following circumstances:

*Power on*

*Duty cycle correction on/off or value changed*

*Power offset on/off or value changed*

*Relative power measurement on/off*

*DVM display enabled*

### Low

In power meter mode, sets the peaking meter sensitivity to  $\pm 10$  dB full scale reading with respect to the centre position.

### Med

In power meter mode, sets the peaking meter sensitivity to  $\pm 5$  dB full scale reading with respect to the centre position.

### Hi

In power meter mode, sets the peaking meter sensitivity to  $\pm 2.5$  dB full scale reading with respect to the centre position.

## Utility

The menus accessed by pressing the [UTILITY] key provide functions for setting the LCD contrast and instrument auto power-off mode. Facilities are also provided for performing tests on the keyboard and LCD.

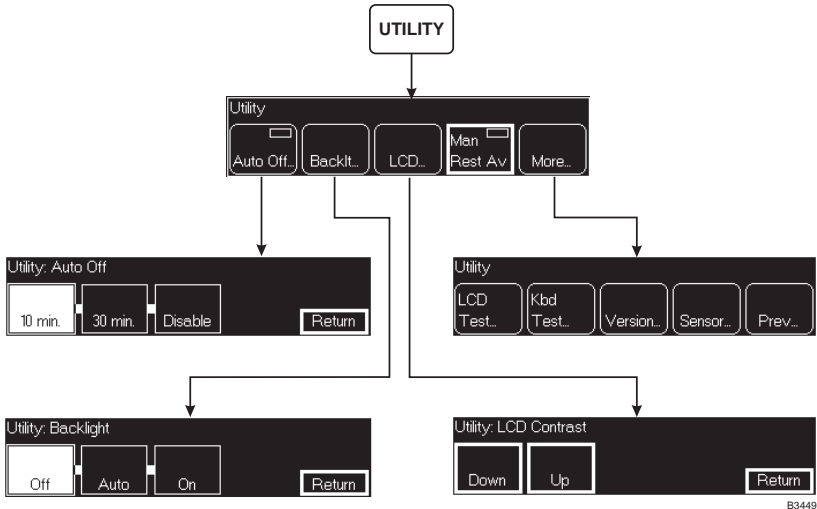

### Auto Off

Leads to a sub-menu which enables the auto power-off feature to be activated. The instrument switches off automatically if there have been no keypresses for the specified time-out period. The following soft keys are displayed:

**10 min.** Sets the time-out period to 10 minutes.

**30 min.** Sets the time-out period to 30 minutes.

**Disable** Disables auto power-off.

**Return** Returns to the Utility top level.

### Backlt...

Leads to a sub-menu which provides control of the LCD backlight. The following soft keys are displayed:

**Off** Turns the backlight off.

**Auto** Turns the backlight on, but will be automatically turned off after a fixed period of time, as defined in the Auto Off menu (above).

**On** Turns the backlight on.

**Return** Returns to the Utility top level.

---

<b>LCD...</b>	<p>Leads to a sub-menu which enables the contrast of the LCD to be changed. The contrast setting is retained in non-volatile memory when the instrument is switched off. The following soft keys are displayed:</p> <p><b>Down</b> Decreases the contrast of the LCD</p> <p><b>Up</b> Increases the contrast of the LCD</p> <p><b>Return</b> Returns to the Utility top level.</p>
<b>Man Rest Av</b>	<p>Disables the auto restart averaging function of the power meter; averaging can then be started manually using the <b>[RESTART AVERAGE]</b> key. In this mode, <b>Man Av</b> is displayed in the power readout area. Averaging is described under 'Making power measurements' later in this chapter.</p>
<b>LCD Test...</b>	<p>Pressing this soft key provides alternate vertical bands of light and dark on the display to confirm that all pixels are functioning correctly. Pressing soft keys 1 to 4 causes the light and dark areas to switch over; pressing soft key 5 returns to the Utility menu.</p>
<b>Kbd Test...</b>	<p>Enables the user to confirm that all front panel keys are working. A representation of the location of the keys on the front panel is shown on the display. When a key is pressed the corresponding location on the display turns dark to indicate that the keypress has been detected.</p>
<b>Version...</b>	<p>Provides information on the version numbers of the instrument software (this is also displayed at power on).</p>
<b>Sensor...</b>	<p>Displays a box containing the following information on the sensor that is currently in use:</p> <p><i>Sensor type</i> <i>Lin Factor</i> <i>Cal Factor</i> <i>50 MHz Cal Factor</i></p>

## Switching on

The instrument is activated by pressing the power on/off key for approximately one second. At power on the instrument briefly displays information on the versions of software installed, and indicates whether or not an external frequency reference has been detected. Also displayed are the results of self tests carried out by the instrument on the internal ROM, RAM and the non-volatile RAM used for storing power-down instrument settings.

In the event of a self test failure (or if a key is pressed during switch on), this information is left displayed on the screen until a key is pressed. The instrument will then continue with normal operation as far as possible (unless the fault is of a fatal nature). If the data in the non-volatile RAM has been found to be corrupted, it is overwritten with default data.

If the batteries require charging (less than 25% full charge), the LED adjacent to the on/off switch will flash. The battery condition is monitored during operation of the instrument, and the percentage of battery life remaining is continuously displayed. The supplied AC adapter can be used to both charge the internal batteries and power the unit. Alternatively, the discharged battery pack can be replaced with a spare one (available as an optional accessory); the battery that has been removed can then be recharged using the optional desktop battery charger.

During battery operation, the auto power-off feature can be enabled to conserve battery power; the instrument will switch off automatically if there have been no keypresses for a specified period (this feature is accessed via the [UTILITY] key..

**Note**

**A fully discharged battery may not be detected by the CPM, preventing charging. Refer to ‘Notes on the internal battery’ in Chapter 2 for the procedure to be followed in this case.**

## Making frequency measurements

Apply the signal to be measured to the COUNTER connector, using an appropriate cable. Note that optimum accuracy is reached immediately after switch on, and the instrument does not require a warm up period.

**CAUTION**

Ensure that the signal level does not exceed the input damage level of +27 dBm. For correct operation the input level should not exceed +10 dBm.

Since the accuracy of the measurement depends on the frequency reference used, more accurate frequency measurements can be made by connecting a suitable external frequency standard to the rear panel EXT 10 MHz input. When an external reference is first connected or removed a message will be displayed for a short period to alert the user.

## Using the counter features

### Frequency resolution

The resolution (i.e. number of digits) to which the counter readout is displayed can be selected by pressing [COUNTER] [Res]. Using the [Down] and [Up]

soft keys the resolution can be set between 1 Hz and 1 MHz in decade steps. Note that the measurement response time increases as the resolution.

## Limit checking

Limit checking can be used to determine if the frequency of a signal is within specification. Upper and lower limits can be defined and a pass/fail indication is displayed above the frequency measurement. An audible warning is also given if the frequency is outside the limits.

The limits are specified in the form of a pass band using the Centre and Delta parameters, i.e. Centre frequency  $\pm$  Delta frequency.

As an example, assume that the nominal frequency is 10 GHz and the allowable deviation from this value is  $\pm 5$  kHz. To test for this, set up limit checking as follows:

```
[COUNTER]
[Limits]
[Centre]
[1] [0] [GHz]
[Delta]
[5] [kHz]
```

The instrument will automatically turn on limit checking and return to Counter menu once the delta value has been entered. To disable limit checking, press [COUNTER] [Limits] [Limits  $\bar{u}$ ].

Note. For relative and offset measurements it is the displayed frequency that is compared with the limits.

## Relative and offset measurements

It is often convenient to measure frequency as a change or offset from a fixed value, or from a reference measurement made earlier. [COUNTER] [Relative] causes the current frequency measurement to be stored and subsequent measurements are made relative to this value. That is

$$\text{Displayed frequency} = \text{Measured frequency} - \text{reference frequency}$$

This feature can be used to measure frequency drift, for example.

Note. When making relative measurements, ensure that the resolution is set to an appropriate value for the displayed frequency.

A positive or negative offset can be applied to the measured frequency before it is displayed. That is

$$\text{Displayed frequency} = \text{Measured frequency} + \text{offset}$$

For example, if a 10 MHz offset is required, press:

```
[COUNTER]
[Offset]
[1] [0] [MHz]
```

The instrument will automatically turn on offset measurements and return to the Counter menu when the terminator key is pressed. To disable the offset, press [COUNTER] [Offset] [Offset  $\square$ ]

## Making power measurements

### Sensor correction and calibration

Conventional power sensors require two values to be entered into the instrument in order enable accurate power measurements to be made:

**Linearity factor.** This is entered once when the sensor is connected, and is a correction figure to allow for the non-linearity of the sensor's response to high power levels. The Linearity Factor is shown on the sensor's label or, more precisely (to two decimal places), on the calibration data chart which accompanies each sensor.

**Calibration factor.** This is a correction figure which takes into account the variation in efficiency of RF to DC conversion in the sensor over its specified frequency range. A graph of Cal Factor against frequency is given on the side of each sensor and the calibration data chart gives Cal Factor at appropriate frequency intervals to two decimal places. The accuracy of the power reading can be improved by entering the Cal Factor from the graph corresponding to the frequency of the measurement. The Cal Factor is applied as follows:

$$\text{Corrected Power} = \frac{\text{Measured Power} \times 100}{\text{Cal Factor} (\%)}$$

Prior to making a measurement, the sensor is calibrated at 50 MHz, and the calibration factor at that frequency is shown separately on the label (Reference Calibration Factor). This must be entered before the sensor is calibrated against the built-in power reference.

As part of the calibration process the sensor must be zeroed. This is done with no RF power applied to the sensor and compensates for any residual voltages present in the sensor / power meter combination. Sensor zeroing is carried out automatically when the 50 MHz calibration is performed (Sensor Cal menu), but a soft key is provided to enable zeroing to be performed at any time.

### Measurement procedure

- (1) Select a sensor appropriate for the power and frequency range of the signal to be measured, and connect it via the sensor cable to the SENSOR INPUT connector.
- (2) Enter the sensor **Linearity Factor** (0.01 to 15) :  
[SENSOR CAL]  
[Lin Factor]  
enter the required value  
[ENTER]
- (3) Enter the sensor **Reference Calibration Factor** (0.01 to 200) :  
[50 MHz CF]  
enter the required value  
[ENTER]

**Note...**The currently stored values for the above parameters can be displayed by pressing [UTILITY] [*Sensor*].

- (4) Connect the sensor to the 50 MHz, 1 mW POWER REFERENCE connector.

The low power 6920 series sensors are calibrated at -30 dBm. The supplied 30 dB attenuator must be used between the power reference output and sensor during calibration

When using 6930 Series Option 002 sensors the supplied 10 dB attenuator must be removed before connection to the power reference output and then reconnected to the sensor before any subsequent measurements.

Press [*Cal*] to calibrate the sensor. The instrument turns off the power reference and initiates zeroing of the sensor; when this is completed, the power reference is turned on and sensor calibration is performed.

Switching the power reference on with the sensor still connected after the above process is a useful check of the calibration quality.

- (5) The calibration factor must now be set to the correct value for the signal that is to be measured (0.01 to 200). For example, if the power level of a 14 GHz signal is to be measured, read the calibration factor for 14 GHz from the sensor label.

**[POWER METER]**

**[*Cal Factor*]**

enter the required value

**[ENTER]**

6910 series and 6930 series power sensors are now ready for making corrected power measurements. When using 6920 series sensors, continue with steps (7) and (8).

- (7) With the sensor still connected to the power reference, perform a sensor zero (the RF is turned off automatically during this operation):

**[SENSOR CAL]**

**[*Zero*]**

- (8) Where feasible, connect the sensor to the signal source to be measured, ensuring no RF power is applied to the sensor, and repeat the zero function by pressing [*Zero*] again.

## Using the power meter features

### Peaking meter

A peaking indicator is provided alongside the power readout, in the form of a representation of an analogue meter. The sensitivity can be set to one of three values using the Peaking Meter menu ( 5, 10 or 20 dB full scale). The meter can also be reset such that the current power measurement will give half full scale reading.

The analogue representation is not for measurement, but enables changes in the power level to be seen more easily than with the digital display. It is normally used for tuning and peaking power levels.

## Limit checking

Limit checking can be used to determine if the power level of a signal is within specification. Upper and lower limits can be defined and a pass/fail indication is displayed above the power measurement. An audible warning is also given if the power level is outside the limits.

As an example, assume that the power levels are required to be in the range -5 dBm to +5 dBm. To test for this, set up limit checking as follows:

```
[POWER METER]
[Limits]
[Max]
[5] [ENTER]
[Min]
[-] [5] [ENTER]
```

The instrument will automatically turn on limit checking and return to the Power Meter menu once the Min limit value has been entered. To disable limit checking, press [POWER METER] [Limits] [Limits] □

Limits can be entered when either logarithmic (dBm) or linear (W) measurements are in use, but the numeric entries must be in dBm

**Note.** For relative and offset measurements it is the *displayed* power that is compared with the limits.

## dB relative and offset measurements

Pressing [POWER METER] [dB Rel] causes the current power level in dBm to be stored and subsequent power measurements are made relative to this value. That is

$$\text{Displayed power (dB)} = \text{Measured power (dBm)} - \text{reference power (dBm)}$$

This feature can be used to measure drift in power level, for example.

A positive or negative offset can be applied to the measured power level before it is displayed. That is

$$\text{Displayed power (dB)} = \text{Measured power (dBm)} + \text{offset } (\pm \text{dB})$$

A typical application is to obtain a true reading of a power level which is too high for the sensor in use, and has therefore had to be attenuated before measurement. In this case, the attenuation figure (in dB) should be entered as a positive number. Similarly, when allowing for an amplifying device, the offset is entered as negative value. For example, if a 10 dB amplifier is used, press:

```
[POWER METER]
[Offset]
[-] [1] [0] [ENTER]
```

The instrument will automatically turn on offset measurements and return to the Power Meter menu when **[ENTER]** is pressed. To disable the offset, press **[POWER METER] [Offset] [Offset □]**

Offsets can be entered when either logarithmic (dBm) or linear (W) measurements are in use, but the numeric entries must be in dB.

Note that for dB relative measurements, dBm units will be changed to read dB.

## Duty cycle correction

The power meter measures the average power of an RF signal. To measure the peak power of a pulsed (rectangular) signal, correction must be applied to compensate for the duty cycle of the waveform. Duty cycle is defined as the percentage ratio of RF on time to RF off time; values in the range 0.001% to 100% can be accommodated. The instrument calculates peak power using:

$$\text{Peak Power} = \text{Average Power} \times 100 / \text{Duty Cycle}$$

Duty cycle correction is applied as follows:

**[POWER METER]**  
**[Duty Cycle]**  
 enter the required value  
**[ENTER]**

The instrument will automatically turn on duty cycle correction and return to the Power Meter menu when **[ENTER]** is pressed. To disable it, press **[POWER METER] [Duty Cycle] [Duty Cycle □]**

Remember to disable duty cycle correction when making normal (non-pulsed) measurements.

Note that with duty cycles other than 100%, the auto restart averaging function is disabled; averaging can be restarted manually using the **[RESTART AVERAGE]** key.

## Averaging

Averaging is used to reduce the effects of noise on power measurements. A number of samples of power level are taken and the average value calculated and displayed. The instrument automatically determines the amount of averaging required depending on the type of sensor connected and the power level being measured.

If a large step change in power level occurs it could take many seconds before the measurement settles to a new level. To overcome this, the averaging function is automatically re-started whenever the RF input level changes by a pre-determined amount. To prevent problems when measuring power levels near the noise floor, automatic restart averaging can be disabled by pressing

**[UTILITY] [Man Rest Av]**

The averaging process can then be restarted manually by pressing the **[RESTART AVERAGE]** key.

### Sensor overload warnings

Should the RF power incident on a 6910 or 6920 series power sensor exceed the stated maximum input level for the sensor, a warning message will be displayed. The RF source should be removed promptly to avoid damaging the sensor. Overload warnings will not be displayed for 6930 series high power sensors.

### Low level power measurements

A 6920 series power sensor used with the Counter Power Meter is an extremely sensitive measuring system capable of reading power levels as low as -60 dBm. It is therefore necessary to follow a few simple precautions to ensure an accurate reading at these low levels.

- (a) Allow the sensor to stabilize to ambient temperature before attempting to start the calibration and measurement.
- (b) Ensure the sensor is not subjected to changes of temperature during the calibration and measurement. For example, handle the sensor as little as possible and do not carry out the measurement in a stream of hot air from an instrument.
- (c) Immediately prior to the measurement perform the following in the given order:

Connect sensor to the power reference via the supplied 30 dB attenuator

Press: **[SENSOR CAL]**

*[Cal]*

*[Zero]*

and where feasible, connect sensor to the signal source to be measured ensuring no RF is applied to the sensor

*[Zero]*

- (d) During the measurement, ensure that the power reference is switched off to prevent RF radiation being picked up by the power sensor.

### Voltage measurements

When the **[DVM]** key is pressed, the power readout is replaced by a measurement of the DC voltage present at the front panel DVM terminals (10 V maximum). The input impedance is 6 M $\Omega$ . The peaking meter functions in the same way as for power measurements, with the sensitivity selectable via soft keys. Note that the negative DVM terminal is connected to the instrument chassis (via a 10 k $\Omega$  resistor), and will therefore be at the same ground potential as the system being measured if either the counter or power sensor inputs are connected to the system.

## Power-down instrument settings

When the instrument is switched off, the current instrument settings are stored in non-volatile memory. When the instrument is next switched on, a checksum test is made of the memory contents, and if successful the stored parameters are re-established. If the test fails the stored values are reset to their default values, as shown below:

### Default settings

Parameter	Setting
Counter frequency resolution	1 kHz
Frequency offset	0 Hz
Frequency limit: Centre	50 MHz
± Delta	±5 MHz
Frequency limits enable/disable	Off
Power offset	0 dB
Power limit: Upper	0 dBm
Lower	0 dBm
Power limits enable/disable	Off
Power units	dBm
Duty cycle	100%
Duty cycle correction enable/disable	Off
Peaking meter resolution	Low
Linearity factor	8
Cal factor	100%
Power reference on/off	Off
Auto power off	10 minutes
Manual restart averaging	Off

---

## Chapter 4

# BRIEF TECHNICAL DESCRIPTION

### Contents

Introduction.....	4-1
Counter.....	4-1
Power meter .....	4-2
Microprocessor control .....	4-3
Power supply.....	4-3

### List of figures

Fig. 4-1 Block diagram of the Counter Power Meter, Sheet 1 .....	4-5
Fig. 4-2 Block diagram of the Counter Power Meter, Sheet 2 .....	4-6

### Introduction

The Counter/Power Meter comprises six printed circuit boards as follows:

RF PCB - contains the counter circuitry.

Processor PCB - contains the main processor that controls the overall operation of the instrument, the gated counter used for frequency measurements, switched-mode power supply and battery management circuitry.

Graphics PCB - provides the drive for the LCD.

Power Meter Processor PCB - contains the processor that controls the power measurement functions.

Power Meter Analogue PCB - contains the data acquisition circuitry for power measurements.

Power Reference PCB - provides the reference signal that is used for calibrating sensors.

### Counter

Frequency measurement in the Counter/Power Meter employs the harmonic heterodyne conversion technique. In general, this type of counter works by mixing the input signal with the Nth harmonic of a local oscillator, which is swept in frequency until an IF signal of the right frequency and level is detected. The down-converted signal is then counted by conventional methods using a gated counter. To determine the correct frequency of the input, the harmonic number N must be found. This is done by making two or more measurements using the same N; this provides the information required by the microprocessor to compute the value of N.

In order to achieve adequate sensitivity, the noise on the IF signal is reduced by reducing the IF bandwidth. This is done by adding a second mixer stage to convert the IF to a second, higher IF value. The use of a second IF also has the advantage of rejecting spurious IF products, enabling the counter to operate at higher input levels. Measurement of the input frequency is performed by counting the second IF, calculating the first IF frequency  $f_{IF1}$  and then calculating the input RF frequency from

$$f_{RF} = N \times f_{LO1} \pm f_{IF1}$$

The local oscillator drive comes from a synthesized VCO, with 500 kHz programming resolution. A digitally controlled TCXO is used as an accurate frequency reference for both the local oscillators and the gated counter. A sampling gate is used to convert the input RF signal to a first IF in the range 10 MHz to 400 MHz.

The counter requires a single dominant signal to count successfully. Selectable IF filtering under microprocessor control is used to reduce the level of spurious signals in the IF band generated by the sampling gate. The 200 MHz LPF is used by the counting algorithm to make certain that the sampled signal is not being measured simultaneously with its image signal generated by the sampling gate. The 400 MHz LPF is primarily used to suppress the LO breakthrough from the sampling gate into the first IF strip. The switched low-pass filtering is positioned before the first IF amplification stage to reduce intermodulation products generated by the amplifier. An extra 400 MHz low pass filter is used to reduce the level of LO signal present in the IF signal.

A hardware AGC circuit using an integrator is used to remove level fluctuations in amplitude modulated signals. Any AM depth can be accommodated as long as the minimum level is greater than the minimum sensitivity of the instrument.

When the input frequency is below 330 MHz direct counting is used, i.e. no frequency conversion of the RF. The LO is set to 800 MHz when performing direct counting, and the 400 MHz low pass filter is switched in to reject unwanted IF products.

## **Power meter**

The power meter section has an 8-bit microcontroller which provides control and timing for the power meter circuits and processes measurement data acquired through an analogue to digital converter (ADC). Program code is contained in internal ROM. The microcontroller interfaces with the main system controller on the Processor board, using a serial link.

The power meter uses a signal chopper to provide a pulsed DC voltage which is proportional to the incident RF power and thus allows AC coupled differential amplification. The tuned input amplifier is distributed between the selected sensor and the input amplifier on the Power Meter Analogue PCB.

The second stage amplifier scales the signal as appropriate over four ranges before feeding the ADC, which converts the analogue signal to a digital form suitable for the microcontroller to process and apply corrections.

A digital/analogue converter (DAC) is used as part of the sensor zero operation to minimise and account for system offsets when no RF signal is applied.

The power reference provides a 0 dBm (1 mW) 50 MHz signal from a level controlled oscillator based on a dual gate FET. Thermal compensation techniques are used in the design of the oscillator such that the long term drift of output power due to temperature variations is minimised.

## **Microprocessor control**

The Processor board consists of a microcontroller accompanied by the peripherals that are needed to provide a user interface, and interfaces to the frequency counter and power meter hardware. The microcontroller directs routines concerned with system and function control, accepts instructions from the keypad, interprets and directs then as necessary, carries out calculations and controls the display.

An EEPROM (located on the RF board) provides non-volatile memory for storing instrument settings when the unit is switched off; data is transferred to and from the microcontroller via a serial link. A second serial link enables communication between the microcontroller on the Processor board and that on the Power Meter Processor board.

## **Power supply**

The internal power source is a rechargeable Ni-MH (Nickel Metal Hydride) battery pack, with a nominal voltage of 10.8 V. A switched-mode power supply provides the regulated +5 V, +8 V, +30 V and  $\pm 15$  V power rails required by the analogue and digital circuitry of the instrument. The -5 V required by the power meter circuits is generated on the Power Meter Processor PCB from the +5 V rail.

A battery management circuit is used to control charging of the batteries and to monitor the charge state and battery temperature. The batteries are charged by connecting a DC voltage in the range 10 - 28 V to the DC input connector; this can be derived from either the supplied AC adapter or from a vehicle 12 V battery.

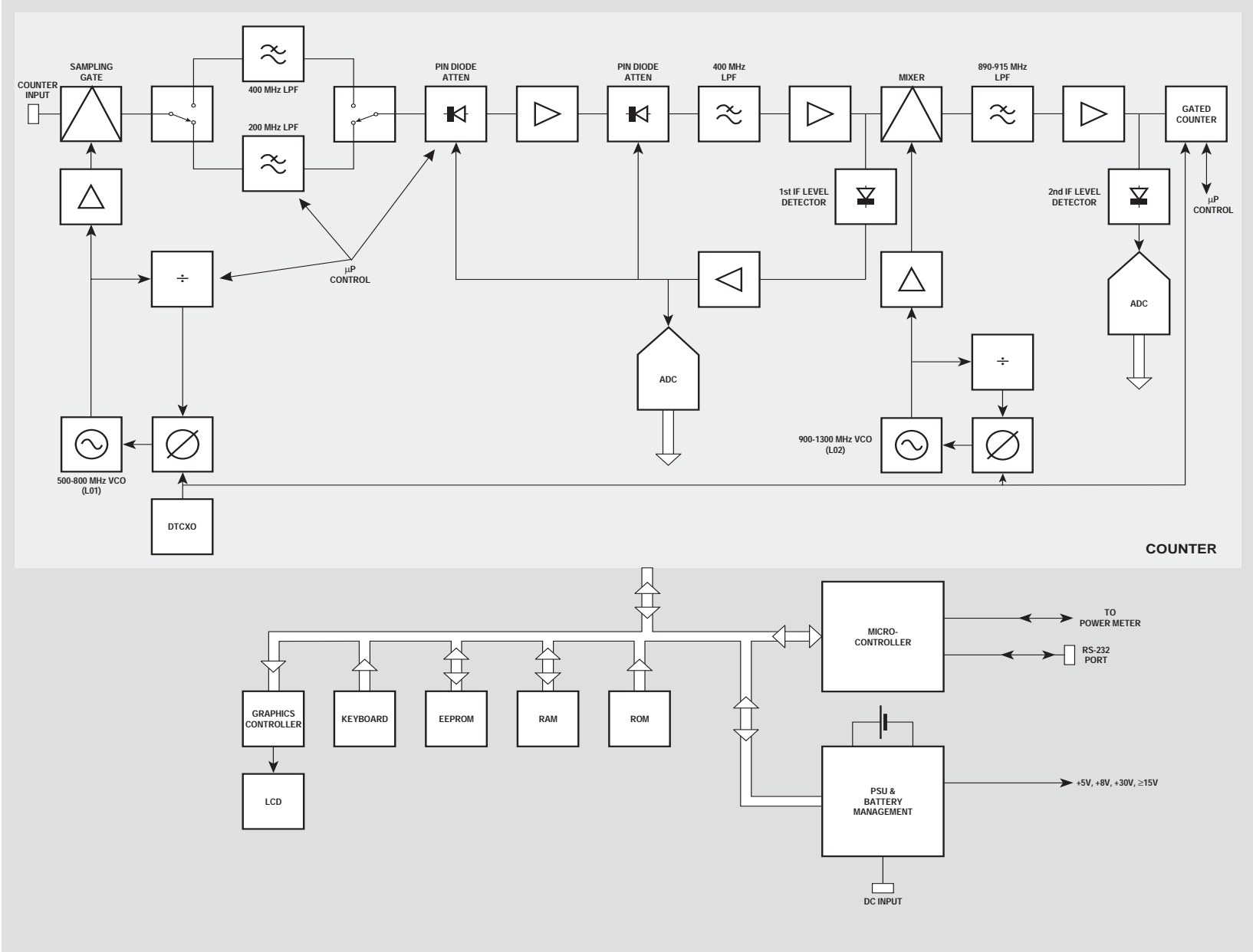

C3470

Fig. 4-1 Block diagram of the Counter Power Meter, Sheet 1

To Printer: Trim A4 printed sheets by 0.53" (13mm) from right edge to clear binder.

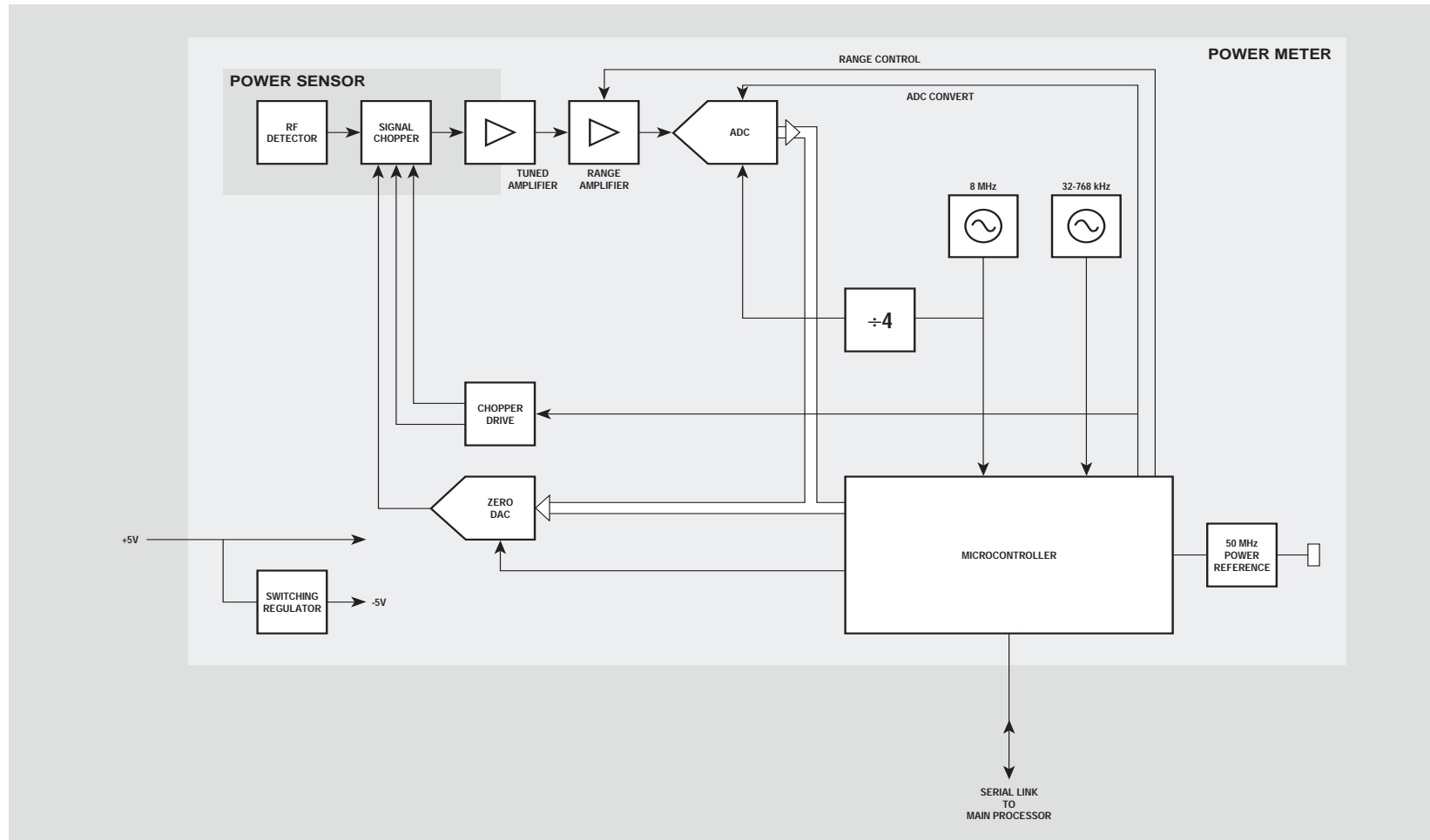

C3471

Fig. 4-2 Block diagram of the Counter Power Meter, Sheet 2

---

# Chapter 5

## ACCEPTANCE TESTING

### Introduction

The following procedure is intended as a quick and convenient method for checking the basic functionality of a new instrument. For a full test of instrument performance against the published specification, refer to the CPM Maintenance Manual.

#### Equipment required

Description	Minimum specification
Power sensor	*IFR 6910, 6920 or 6930 Series
Voltage source	DC voltage in the range 0 to +10 V (e.g. bench power supply)

\*IFR Ltd was previously known as Marconi Instruments Ltd

## 1 Power-on and battery charging

- (1) Before switching on the CPM, connect to the line supply via the AC adapter/ battery charger and check that the battery charging LED, adjacent to the power ON/OFF switch, is lit. (The LED will flash if the battery has less than 25% charge.)
- (2) Press the ON/OFF switch to power-on the CPM. The display should now be present and illuminated by the LCD backlight and the battery charge LED should still be lit.
- (3) Note the battery charge level shown by the battery life indicator at the top right-hand corner of the display. If the battery is discharged (0% indication), allow to charge until the LED no longer flashes. Alternatively, replace the battery with one that is fully charged. Disconnect the AC adapter and check that the CPM continues to operate from battery supply.

**Note**

**A fully discharged battery may not be detected by the CPM, preventing charging. Refer to 'Notes on the internal battery' in Chapter 2 for the procedure to be followed in this case.**

## 2 LCD and keyboard tests

- (1) Press the [UTILITY] key, followed by the [More] and [LCD Test] soft keys. The LCD should display four vertical bands of alternate light and dark areas which can be used to confirm that all pixels are functioning correctly. Pressing soft keys 1 to 4 causes the light and dark areas to switch over; pressing soft key 5 exits the LCD test.
- (2) Press the [Kbd Test] soft key. A representation of the location of the keys on the front panel is shown on the display. When a key is pressed the corresponding location on the display turns dark to indicate that the keypress has been detected. Press the [OK] soft key to exit the keyboard test.

## 3 Counter input and power reference output

- (1) Connect the POWER REFERENCE output to the COUNTER input.
- (2) Turn on the power reference by pressing the [POWER REF] key.
- (3) Check that the counter display reads 50 MHz  $\pm$ 0.05 MHz.

## 4 Power meter zero and calibration

- (1) Connect the power sensor to the SENSOR INPUT connector using the supplied cable. Connect the power sensor input to the POWER REFERENCE output (via the supplied 30 dB attenuator if using a 6920 series sensor).
- (2) Press the [SENSOR CAL] key, followed by the [Cal] soft key to perform a sensor calibration (the instrument performs a zero first).
- (3) Turn on the power reference by pressing the [POWER REF] key.
- (4) Check that the power meter display reads 0 dBm  $\pm$ 0.05 dBm (-30 dBm  $\pm$ 0.05 dBm for 6920 series sensor).

## 5 DVM input

- (1) Press [DVM] to select voltage measurement.
- (2) Connect the voltage source to the DVM input and check that the correct voltage is displayed.

---

# INDEX

## A

AC adapter 1-3, 2-1, 3-20  
Accessories 1-11  
Auto power-off 1-3  
Auto-off function 3-18  
Averaging 3-25

## B

Backlight 3-18  
Battery charging 1-3, 2-1, 2-5

## C

Cal factor 3-11, 3-15  
Calibration 3-15, 3-22  
Contrast 3-19  
Counter functions 3-9  
Counter resolution 3-9, 3-20

## D

Data entry 3-7  
DC supply 1-3, 2-1  
Default settings 3-27  
Display 3-5  
    Backlight 3-18  
    Contrast 3-19  
    Test 3-19  
Duty cycle correction 3-12, 3-25  
DVM measurements 3-16, 3-26

## F

Features  
    Frequency measurements 1-1  
    Front panel 3-2  
    Front panel keys and display 3-5  
    General 1-3  
    Power measurements 1-2  
    Rear panel 3-4  
Frequency measurements 3-20  
Frequency offset 3-9, 3-21

## I

Instrument settings 1-3, 3-27

## K

Keyboard test 3-19

## L

Limit checking  
    Frequency 3-10, 3-21  
    Power 3-12, 3-24  
Linearity factor 3-15  
Low level power measurements 3-26

## P

Peaking meter 3-16, 3-17, 3-23  
Performance data  
    Digital voltmeter 1-7  
    Frequency measurements 1-4  
    General 1-7  
    Power measurements 1-5  
Power meter functions 3-11  
Power offset 3-12, 3-24  
Power reference 1-2  
Power requirements 1-3, 2-1

## R

Relative frequency measurements 3-9, 3-21  
Relative power measurements 3-11, 3-24

## S

Sensor calibration functions 3-15  
Sensor overload 3-26  
Supported power sensors 1-11  
Switching on 3-20

## U

Units 3-14

## V

Voltage measurements 3-16, 3-26

## Z

Zeroing 3-15, 3-22